



VENIERI
SPA

HIGH
EFFICIENCY | **HE**

7.63D
8.63C
9.63D
10.63D
WHEEL LOADERS



STAGE 5



prosemya/official



www.vf-venieri.com



vf_venieri



vfvenieri



vfvenieri



VF Venieri



vf-venieri-spa



VENIERI SPA
EARTHMOVING MACHINES

Via Piratello, 106 - 48022 Lugo (RA) - ITALY
Tel. +39 0545 904411 Fax +39 0545 30389
e-mail: info@vf-venieri.com | www.vf-venieri.com

SPARE PARTS

Tel. +39 0545 904429 Fax +39 0545 24555
e-mail: ricambi@vf-venieri.com

The illustrations on the present folder do not necessarily show the product standard version. Data and dimensions described in this folder are not binding. Venieri reserves the right of carrying out possible changes at any time and without previous notice because of its policy of steady development and improvement of the products.

UP7630_9630_8630HL_10.630_A-EN (2021)

7.63D
9.63D

BUILDING, CONSTRUCTION AND INDUSTRY



KINEMATICS 4K

Latest generation kinematics, completely redesigned to guarantee maximum breakout force.



SAFETY IS OUR PRIORITY

The front axle internally integrates the negative/automatic parking brake for maximum safety in every operating situation.



**CYCLONE
PRE-
FILTRATION**

CLEAN AIR AT ALL TIMES

Engine air filtration takes place via the main cartridge, safety cartridge and cyclone pre-filtration.



SILENT OPERATION

The commitment of Venieri's R&D in terms of noise reduction has resulted in a decrease of noise pollution below 70 dB; this value was certified on previous models and guarantees the operator maximum operating comfort.

360°



BREATHTAKING VIEW

The new ROPS/FOPS Level II certified cabin guarantees 360° visibility, allowing total visual control over any equipment installed.



STAY COOL

The new ventilation system guarantees maximum comfort to the operator. You can choose between automatic climate control or air conditioning, thus obtaining the perfect temperature in the cabin.



100% VENIERI DESIGN

Maximum attention by the Venieri Style Center in preserving a "family feeling", despite the introduction of a Stage V engine with substantially larger dimensions than the previous Stage IIIB.



VENIERI DASH CONTROL

With the color electronic dash control the operator will be able to easily manage the electronic transmission, the available options and the reading of the transmission pressure.



STAGE 5



DEUTZ STAGE V / TIER 4f ENGINE

New Deutz engine, compliant with the latest anti-pollution regulations with high torque already at low rpm. Substantial increase in power up to 21% and torque up to 17%, compared to previous models.



DOUBLE SPEED

DOUBLE ATTENTION FOR SAVINGS

Electrically controlled and hydraulically operated double speed cooling fan. Rotation speed according to working conditions: reduced fuel consumption and low noise.



TOTAL STABILITY

All new Venieri loaders are equipped with an oscillating rear axle supported by maintenance-free supports.



VENIERI GLOBAL

VENIERI GLOBAL

Being connected is no longer optional for us. Thanks to the (standard) integrated Venieri Global system, the new Venieri loaders and your Smartphone become one. (Venieri Global annual subscription not included).



“SHIFT ON FLY” MECHANICAL GEARBOX

2-speed mechanical gearbox, with variation of the mechanical speed ratio and electronic shifting management (On VF 9.63D. On VF 7.63D the gear change is synchronized from standstill).



SMART FORWARD MOTION

Specific driving mode for the use of equipment that requires maximum oil flow combined with the possibility of low-speed transfers. Manageable transfer either by using the Venieri Dash Control or directly from the pedal, allowing the operator full control of vehicle and equipment, without ever taking his hands off the steering wheel.



AGILE BY VOCATION AND DESIGN

The particular design of the counterweight has been studied to obtain extremely high angles of operation, protect the LED street lights, ensure maximum maneuverability in tight spaces and prevent the ground from sticking when operating off-road.

8.63C
10.63D

BORN FOR
AGRICULTURAL USE



PARALLEL KINEMATICS

Latest generation kinematics, which guarantees parallel operation with the forks along the entire arm movement range.



SAFETY IS OUR PRIORITY

The front axle internally integrates the negative/automatic parking brake for maximum safety in every operating situation.



CLEAN AIR AT ALL TIMES

Engine air filtration takes place via the main cartridge, safety cartridge and cyclone pre-filtration.



SILENT OPERATION

The commitment of Venieri's R&D in terms of noise reduction has resulted in a decrease of noise pollution below 70 dB; this value was certified on previous models and guarantees the operator maximum operating comfort.



BREATHTAKING VIEW

The new ROPS/FOPS Level II certified cabin guarantees 360° visibility, allowing total visual control even if equipped with an extended parallel arm.



STAY COOL

The new ventilation system guarantees maximum comfort to the operator. You can choose between automatic climate control or air conditioning, thus obtaining the perfect temperature in the cabin.



100% VENIERI DESIGN

Maximum attention by the Venieri Style Center in preserving a "family feeling", despite the introduction of a Stage V engine with substantially larger dimensions than the previous Stage IIIB.



VENIERI DASH CONTROL

With the color electronic dash control, the operator will be able to easily manage the electronic transmission and the available options, and read the transmission pressure.



STAGE 5

DEUTZ STAGE V / TIER 4f ENGINE



New Deutz engine, compliant with the latest anti-pollution regulations with high torque already at low rpm. Substantial increase in power up to 21% and torque up to 17%, compared to previous models.

TOTAL STABILITY



All new Venieri loaders are equipped with an oscillating rear axle supported by maintenance-free supports.

TIRES FOR EVERY APPLICATION



Wide range of versatile agricultural tires of different sizes, depending on the type of terrain and use.

AGILE BY VOCATION AND DESIGN



The particular design of the counterweight has been studied to obtain extremely high angles of operation, protect the LED road lights, ensure maximum maneuverability in tight spaces and prevent the ground from sticking when operating off-road.



"SHIFT ON FLY" MECHANICAL GEARBOX

2-speed mechanical gearbox, with variation of the mechanical speed ratio and electronic shifting management (On VF 10.63D. On VF 8.63C the gear change is synchronized from standstill).



DOUBLE SPEED

DOUBLE ATTENTION FOR SAVINGS

Electrically controlled and hydraulically operated double speed cooling fan. Rotation speed according to working conditions: reduced fuel consumption and low noise. Reversible fan kit available (optional).



VENIERI GLOBAL

VENIERI GLOBAL

Being connected is no longer optional for us. Thanks to the (standard) integrated Venieri Global system, the new Venieri loaders and your Smartphone become one. (Venieri Global annual subscription not included).



SMART FORWARD MOTION

Specific driving mode for the use of equipment that requires high oil flow combined with low-speed transfers. Manageable transfer via the Venieri Dash Control or directly from the pedal, allowing the operator full control of vehicle and equipment, without ever taking his hands off the steering wheel.

THE CABIN

A BREATHTAKING VIEW.

Take a seat in your customized control room. Create your ideal work space by adjusting the pneumatic seat and the steering wheel to suit your specific needs. Select the commands, all at your fingertips. The excellent all-round visibility in which "blind spots" have been reduced to a minimum, offers the optimal view to work with maximum efficiency, allowing total visual and operational control over any installed equipment.

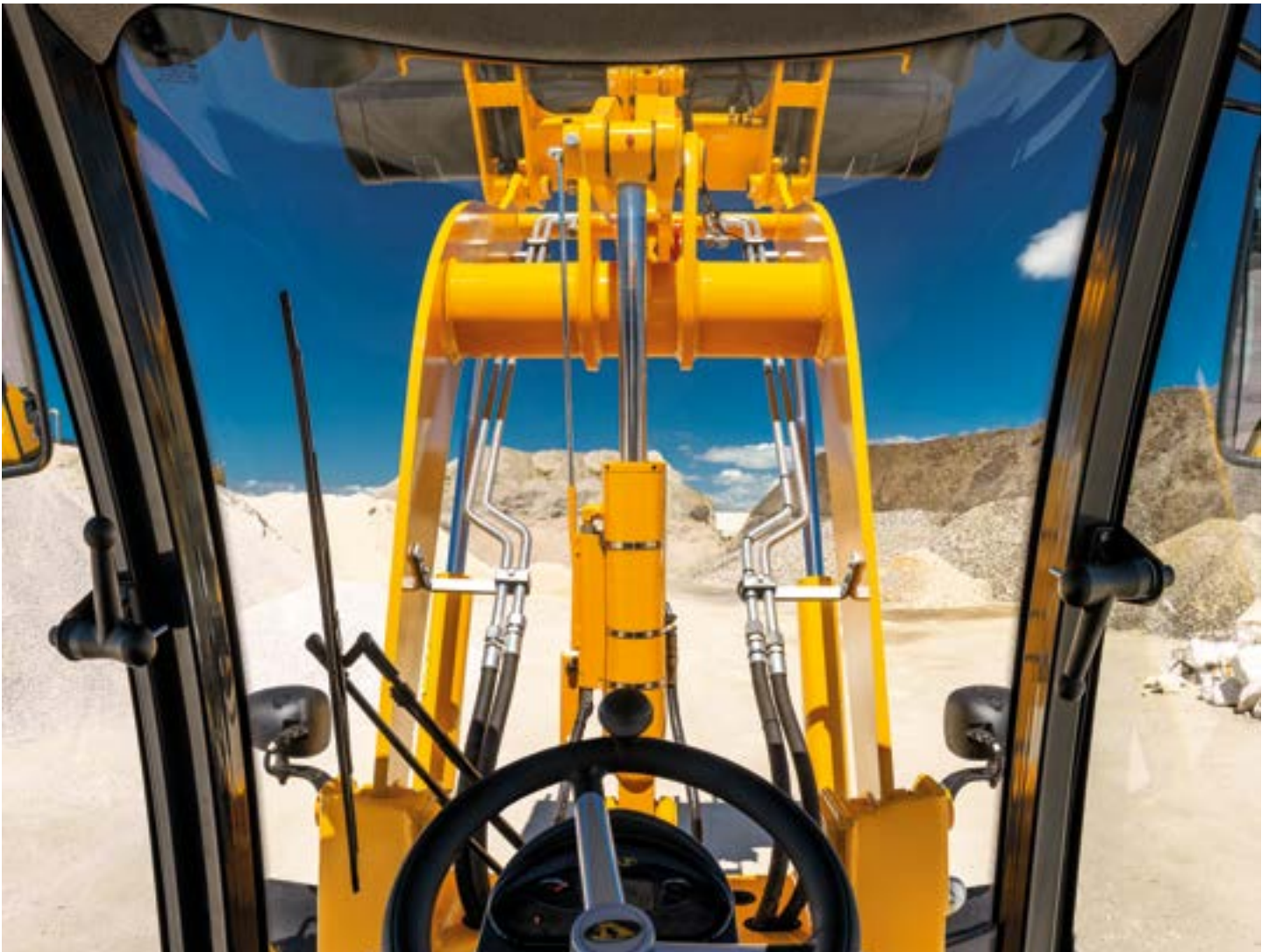

STAY COOL. AT ALL TIMES.

All the ventilation system (with 9 delivery points) has been completely redesigned for alignment to ISO10263 standards, and ensures easy maintenance of the heating and A/C unit, which can be completely tilted out of its housing. Using a single dashboard, the operator can select the ideal temperature, thus achieving maximum working comfort. All the Venieri wheel loaders can be equipped with Venieri Climatronic (optional): you set the temperature... and it will take care of the rest!

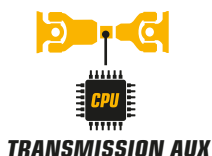
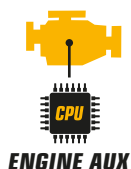
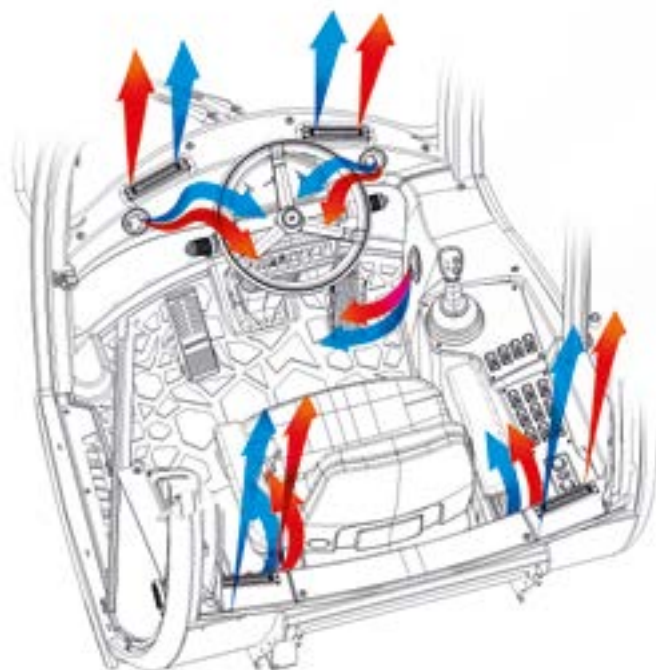

**BLACK
BOX
EASY
ACCESS**

IT'S ALL HERE.

For the first time on a Venieri cabin, all the electronic components have been installed in a watertight box located in the cab frame, and accessible only from inside the passenger compartment; it is easy to access and complete with all the sockets required to perform diagnostics.

OPEN SESAME.

The double-opening door allows the operator to work with the access door closed, but with the upper glass open, thus ensuring maximum ventilation even when the A/C system is off and without protruding parts.



BEAUTY MEETS FUNCTIONALITY AT LAST.

In designing the cabin of the new wheel loaders, the Venieri Style Center tried to blend functionality and style, with the goal of manufacturing top-of-the-line machinery in terms of comfort and ergonomics. The new interior design has also made it possible to obtain various storage areas, which are very useful for storing small work tools, mobile phones, drinks and more.



POWER AND COMMANDS AT YOUR FINGERTIPS.

The mono-joystick* represents the ultimate in all-in-one technology: ergonomics and functionality at the operator's service.

* Optional, available on request.

THE TRANSMISSION

HE A NEW VISION OF HYDROSTATIC EFFICIENCY

The increasingly stringent limits for exhaust emissions will continue to represent an ever-increasing challenge for the further technical development of mobile work machines. In addition, machine operators require increasingly greater efficiency and productivity.

The interconnection between electronic and hydraulic parts is essential in reducing fuel consumption and exhaust emissions, while also increasing the operating performance of the machine.

As a result, the extraordinary evolution of electronics applied to hydraulic power guarantees greater flexibility and a targeted response to address every different operational need more effectively.



SHIFT ON FLY. IT NEVER STOPS.

Mobile machines to support the speeds required in road travel are generally equipped with hydrostatic transmission and a gearbox that can be synchronized or automatic. In the first case (synchronized), the change from working gear to transfer is performed while stationary, while in the second case (SoF = automatic) the change takes place in motion.

The Dana-Rexroth transmission with electronically controlled hydrostatic pump and motor and a 367 SOF - Shift On Fly gearbox, also electronically operated, offers new opportunities for road driving, especially for wheel loaders. It allows the operator to operate at low speed with high traction forces, and later, during the transfer, change the mechanical ratio in torque, without stopping the machine, to reach a maximum speed of 40 km/h (self-limited).



- **GREATER EFFICIENCY: HIGH TRACTION FORCE AND MAXIMUM TRANSFER SPEED**
- **HIGH COMFORT: FAST AND SYNCHRONIZED GEAR CHANGES WITHOUT INTERRUPTIONS**
- **VERY HIGH RELIABILITY SERIES COMPONENTS**
- **MEETS FUNCTIONAL SAFETY REQUIREMENTS**
- **COMPACT DIMENSIONS, REDUCED INSTALLATION SPACE**

BENEFITS





METHOD OF USE

3 different driving modes are available, each with different characteristics to always guarantee maximum operational efficiency.



ECO



WORK



AUTOMOTIVE



CONTROL MODE

Essential for use with attachments, these modes allow adjusting the machine's forward motion (by power meter or pedal) with all the hydraulic power available for the attachment.



POWER & SPEED



CREEP



CREEP MODE PLUS



ELECTRONIC DASHBOARD

Control the main functions of the machine with a finger. "DASH" digital panel necessary to select ALL the machine transmission modes and settings.



INTUITIVE CONTROLS



EASY TO USE



REAL TIME DIAGNOSTIC

HIGH EFFICIENCY | HE





SAFETY ON BOARD

Several safety controls operated by the Rexroth control unit allow the user to operate in total safety, with maximum efficiency and without the risk of machine downtime.



SELF DIAGNOSIS

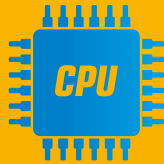

ELECTRONIC TRANSMISSION MANAGEMENT

It guarantees an optimized distribution of the available power to reduce consumption and increase performance.



ARTIFICIAL INTELLIGENCE



INTERCONNECTED MACHINE

A machine totally interconnected and controlled entirely in the Cloud. Welcome to the future.

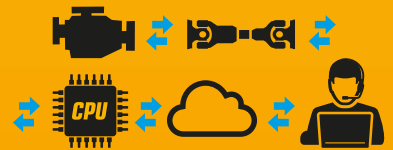

- PREDICTIVE MAINTENANCE
- REAL-TIME DATA & DIAGNOSIS
- SELF-LEARNING
- MACHINE IN CLOUD



VENIERI 4.0.

The VENIERI DASH CONTROL electronic Dashboard allows the operator to manage and view some of the most important functions of the machine with utmost ease and efficiency.

ECO MODE

ECO mode control screen, for a "softer" setting of the transmission response curve and limitation on engine RPM at max 1700 RPM



INSTANT CONSUMPTION
RESIDUAL OPERATION

CREEP PLUS

SMART FORWARD MOTION

Essential for use with attachments, these modes allow adjusting the machine's forward motion (by power meter or pedal) with all the hydraulic power available for the attachment.



ENGINE LOAD
TURBO PRESSURE

AUTOMOTIVE

AUTOMOTIVE mode control screen, in which we have an average setting of the transmission response curve and all available engine revolutions



ENGINE LOAD

WORK

WORK mode control screen, in which we have the inhibition of the shifting, first gear from 15 km/h instead of 10 km/h and setting for the response curve of the more "aggressive" transmission



TRANSMISSION ERRORS
TRANSMISSION PRESSURES

DIAGNOSTIC

Screen for checking diagnostic errors and pressures.



VENIERI
DASH
CONTROL



MANUAL ACCELERATOR

Engine RPM display and control screen for use with attachments



ALL-SEASONS MACHINE.

The multifunction properties of the new loaders is achieved with the single multifunction connection plate, an essential implementation to make them a universal tool carrier.



69dB
INTERNAL

SILENCE IS A VIRTUE.

The noise level of the new loader is simply extraordinary. With only 69dB of internal noise in the cabin, you will not even realize that you are working; you can also use very convenient options, such as the Bluetooth™ hands-free kit with maximum effectiveness.



40 Km/h
SELF-LIMITED

VROOOOOOOOM!

Driving speed 40 km/h*, self-limited. On the other hand, Venieri is based in the heart of the Italian Motor Valley and... the speed of our machines cannot be an option!

**20 km/h for the German version.*



POWER AND EFFICIENCY WHERE YOU NEED THEM MOST.

A lot of power for the hydraulic system and, at the same time, a reduction in travel speed.

For these reasons the new Venieri wheel loaders need a single pedal. The brake pedal with inching function can control both the mechanical and the hydraulic (inching) brake.

Obvious advantages are less wear on the service brake and optimal distribution of engine power.



NO PRESSURE

on the inching/brake pedal: maximum power for traction.



NORMAL PRESSURE

on the inching/brake pedal: speed reduction, more power in the service hydraulic system.



MAX PRESSURE

on the inching/brake pedal: the wheel loader stops, maximum strength to the hydraulic system

THE ENGINE

MAXIMUM POWER, ECO FRIENDLY ENGINE.

The new Venieri loaders are fitted with a DEUTZ TCD 3.6 L4 motor, which is a compact 4-cylinder in-line and water-cooled motor, for industrial and agricultural machinery, with a maximum power of 143 HP and aligned with EU Stage V and United States EPA Tier 4f requirements.

Externally cooled turbocharged engine with intercooler and exhaust gas recirculation. 100% of the power available on flywheel and front. Up to two hydraulic drives can be installed on the PTO, with a total torque of up to 310 Nm.

EXHAUST GAS MANAGEMENT

The exhaust gas management on this engine is DOC/DPF + SCR.

DOC (Diesel Oxidation Catalyst) is a catalyst that reacts by contact with the engine exhaust gases, transforming its main components into substances that are not harmful to the environment.

The DPF (Diesel Particulate Filter) is a DEUTZ diesel particulate filter, coated with noble metals and adapted to the installation needs of the individual customer application, which supports regular, safe and continuous regeneration, without the need for regular maintenance or additional operating fluids. The use of reliable turbocharger technology, especially compared to SCR-based EAT systems only, enables optimum engine performance throughout the entire rev range. A surface temperature of max. 250°C provides additional safety during operation.

The SCR (Selective Catalytic Reduction) is a method for reducing NOx emissions. The basis of this technology is a 32.5% liquid urea solution, which is sprayed into the exhaust duct by a dedicated vanadium- or zeolite-coated catalyst. Urea produces ammonia (NH₃) in a passive transformation which reacts with NOx and oxygen to form nitrogen and water.

- **MINIMUM CONSUMPTION OF OPERATING LIQUIDS VERSUS THE COMPETITION**
- **500 HOUR MAINTENANCE INTERVAL TO REGENERATE SULFUR DEPOSITS AND ADBLUE CRYSTALLIZATION**
- **TECHNICAL SUPPORT AND DIAGNOSIS PROVIDED BY DEUTZ'S WORLDWIDE SERVICE NETWORK**

BENEFITS

ADVANCED TECHNOLOGY FOR EXHAUST GAS RECOVERY

TECHNICAL OVERVIEW OF THE TIER 4 FINAL CONCEPT

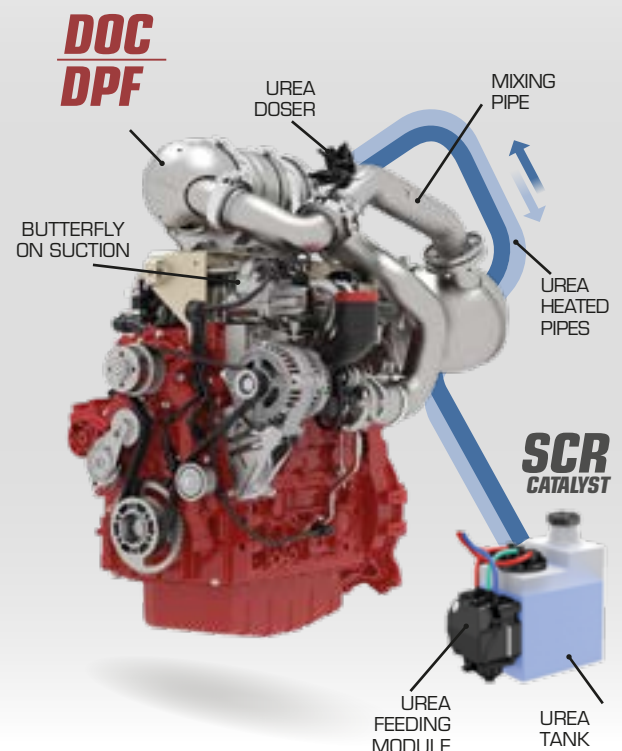

ENGINE MANAGEMENT

Engines equipped with DEUTZ Common Rail® injection communicate with the machine via a CAN-Bus protocol. This allows functions such as drive-by-wire and full engine control to be integrated into electronically controlled hydrostatic thrusters. The automatic electronic control also guarantees the integrated engine diagnosis and safety system. If the controller registers an abnormal motor status, as in the case of overheating, engine performance is

reduced to emergency mode until it shuts down. This minimizes costly repairs, reduces equipment downtime and increases operational reliability.

COMMON RAIL

The powerful Common Rail® injection system and the Electronic Engine Control (EMR) with smart connection to engine management ensure optimum engine performance with low fuel consumption.

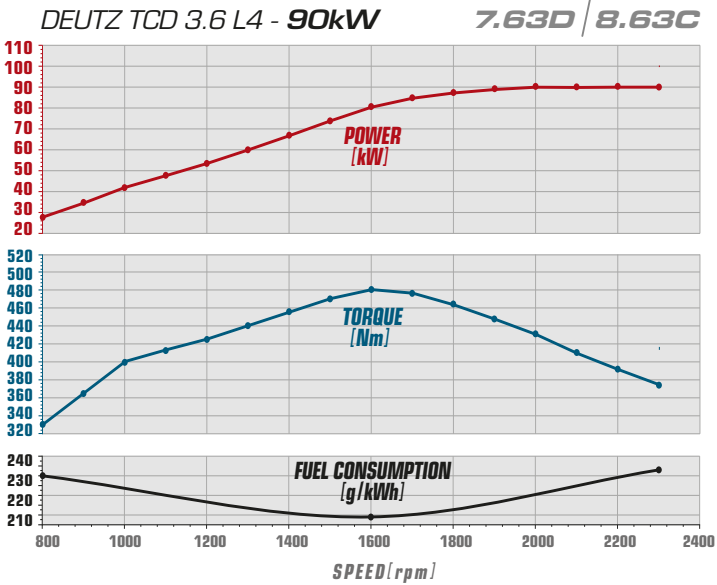
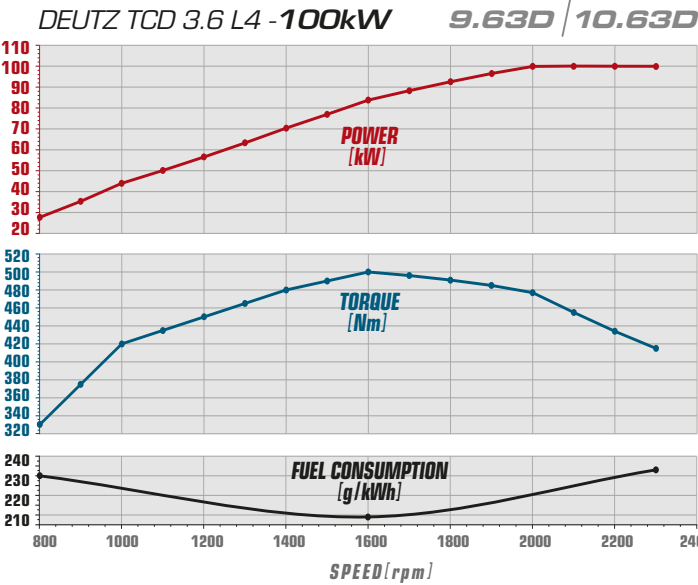

EVOLUTION IN PERFORMANCE

Performance step-up guaranteed by the technological evolution of the brand new Deutz Stage V engine that is installed in the new Venieri loaders is evident in every area of use when compared to the previous generation of wheel loaders. And always with the utmost respect for the environment and consumption.

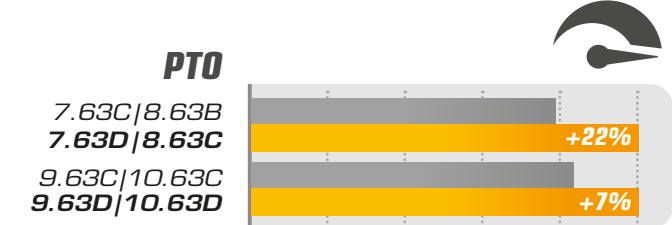
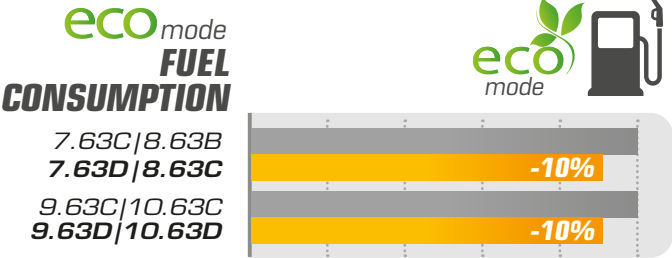
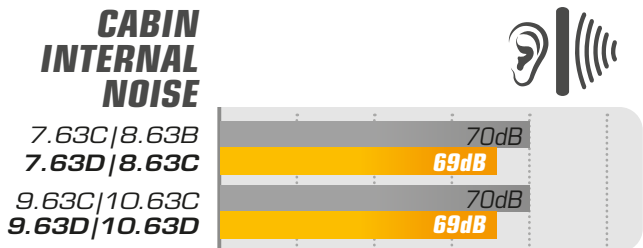
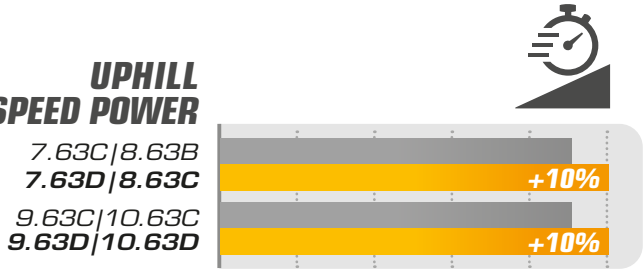
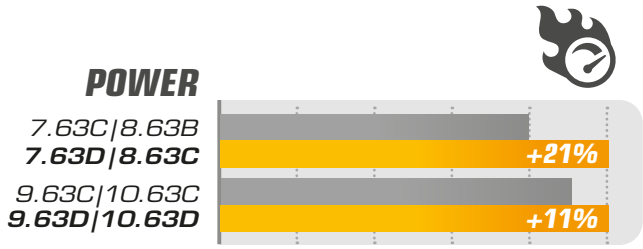

Venieri GLOBAL

CONTROL YOUR FLEET

Venieri GLOBAL™ is our brand-new satellite monitoring system, which guarantees an increase in productivity by providing detailed information about the fleet and attachments, as well as an incredible amount of data to ensure the highest performance levels and greater economic efficiency.

A V A I L A B L E F E A T U R E S

Machine localisation	✓
Alerts history	✓
Maintenance plan	✓
Maintenance history	✓
Load information	✓
Working hours	✓
Security control (engine block)	0
Fuel consumption (total and partial)	✓
Fuel consumption while working	✓
Machine efficiency (while working)	✓
Detailed working hours	✓
Motion sensor alarm	✓
Curfew alarm setting	✓

Work shifts alarm	✓
Standard operating procedure history	0
Energy-saving guidelines history	0
Location log (map with locations and operating procedures)	✓
Information about diesel particulate filter	✓
Geo-fencing	✓
Localisation and management fleet	✓
Multuser control with specific access policies	✓
List of "sleeping" machines	✓
Sms/e-mail notification	✓
Anti-theft alarm	✓
Parameters setting upon request	0

✓ Standad 0 Optional X Not available

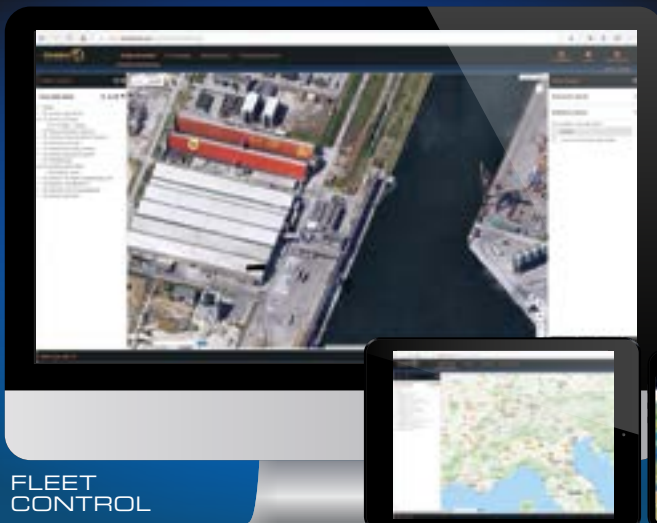

FLEET CONTROL

PRODUCTIVITY REPORT

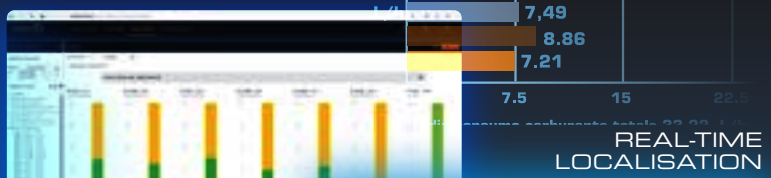

REPORTISTICA: CONSUMO CARBURANTE
DA: 11/10/2018 00:00:00 - A: 11/10/2018

REAL-TIME LOCALISATION



APP FOR SMARTPHONE
IOS™ AND ANDROID™



MACHINE
EQUIPMENT

Battery switch	✓	✓	✓	✓
Maintenance tool set	✓	✓	✓	✓
Diesel preheating for cold start	0	0	0	0
Cap with key for fuel tank	✓	✓	✓	✓
Self-locking proportional differential on the front axle	✓	✓	✓	✓
Self-locking proportional differential on the rear axle	0	0	0	0
Differential with 100% locking on the front axle	0	0	0	0
Tow hook	✓	✓	✓	✓
Rotating lamp	✓	✓	✓	✓
Soundproofing	✓	✓	✓	✓
Spare parts catalogue	✓	✓	✓	✓
Use and maintenance manual	✓	✓	✓	✓
Type approval for operation on roads	✓	✓	✓	✓
Arm and bucket lock safety device	✓	✓	✓	✓
Device for bucket positioning parallel to the ground	✓	✓	✓	✓
CREEP mode	0	0	0	0
CREEP mode Plus	0	0	0	0
Venieri GLOBAL satellite monitoring (Annual subscription not included)	✓	✓	✓	✓
Double-speed hydraulic fan	✓	✓	✓	✓
Reversible fan for radiator cleaning	0	0	0	0
Negative parking brake	✓	✓	✓	✓
Service brake on both decks with separate circuits	✓	✓	✓	✓
Inch pedal integrated on the brake pedal	✓	✓	✓	✓
Greasing points grouped on frames	✓	✓	✓	✓
Automatic centralized greasing	0	0	0	0
Ride control	0	0	0	0
Water preheating system	0	0	0	0
Hydraulic oil preheating system	0	0	0	0
Biodegradable hydraulic oil	0	0	0	0
ISO 46 hydraulic oil (cold climates) (On request in Italy)	✓	✓	✓	✓
Vortex prefilter	✓	✓	✓	✓
LED rear lights	✓	✓	✓	✓
Electronically controlled hydrostatic transmission with 2 modes of use (Automotive and ECO)	✓	✓	X	X
Electronically controlled hydrostatic transmission with 3 modes of use (Automotive, Work and ECO)	X	X	✓	✓
Gearbox with 2 mechanical gears and synchronizer (gearbox from standstill)	✓	✓	X	X
Gearbox with 2 mechanical Shift on Fly ratios selectable on the go	X	X	✓	✓



CABIN
EQUIPMENT

ROPS/FOPS Level II, pressurized and soundproofed cabin	✓	✓	✓	✓
Front and rear windshield wipers with washer	✓	✓	✓	✓
Halogen work lights (4 front + 2 rear)	✓	✓	✓	✓
Work LED lights (4 front + 2 rear)	0	0	0	0
Mobile phone compartment	✓	✓	✓	✓
Bottle holder	✓	✓	✓	✓
Document compartment	✓	✓	✓	✓
Seat with mechanical suspension	✓	✓	✓	✓
Seat with pneumatic suspension	0	0	0	0
Seat with pneumatic suspension and heating	0	0	0	0
Armrests on seat	✓	✓	✓	✓
Buzzer	✓	✓	✓	✓
Cabin carpet	✓	✓	✓	✓
Clothes hangers	✓	✓	✓	✓
radio wiring	✓	✓	✓	✓
Additional 12V socket	✓	✓	✓	✓
"Manual" air conditioning	0	0	✓	✓
"Climatronic Venieri" automatic climate system	0	0	0	0
Internal courtesy light	✓	✓	✓	✓
Sunblind	✓	✓	✓	✓
Rear-view mirrors	✓	✓	✓	✓
Heated rear-view mirrors	0	0	0	0
First-aid kit	0	0	0	0
2 kg fire extinguisher	0	0	0	0
Safety seat belt	✓	✓	✓	✓
Instrumentation and dashboard complete with LCD display	✓	✓	✓	✓
Venieri Dash Control	✓	✓	✓	✓
Glass breaker hammer	✓	✓	✓	✓



EQUIPMENT

Hydraulic or mechanical quick coupler	0	0	0	0
Mixing bucket	0	0	0	0
4-in-1 multipurpose bucket	0	0	0	0
Universal lifting forks	0	0	0	0
Asphalt/concrete planner	0	0	0	0
Snow blower	0	0	0	0
Snow blade or "V" blade	0	0	0	0
Angle-tilt dozer	0	0	0	0
Hand hammer	0	0	0	0
Sweeper	0	0	0	0
Trencher	0	0	0	0
High-tip bucket	0	0	0	0
High-flow system	0	0	0	0
Unpressurized return line	0	0	0	0
Double auxiliary system	0	0	0	0
Rear hydraulic outlets (single effect)	0	0	0	0

NOTE - standard configuration may vary from market to market: please, always verify with the dealer.

✓ Standard 0 Optional X Not available

7.63D

Z KINEMATICS



DIESEL ENGINE

4 in-line cylinders, supercharged, charge air cooling, electronically controlled, common-rail injection, exhaust gas recirculation, water cooling, dry filtration, oxidation catalyst (DOC) particulate filter (DPF) and selective catalytic reduction (SCR). Issued according to EC Directive 97/68 - Stage V/Tier 4f.

Type	Deutz TCD 3.6 L4
Max. power	94,5 kW - 128 HP
Calibration (RPM)	2.300
ISO/TR 14396 power	90 kW - 122 HP
EEC 80/1269 power	90 kW - 122 HP
Maximum torque	Nm 480
Bore	mm 98
Stroke	mm 120
Displacement	cm³ 3.620



ELECTRIC SYSTEM

Battery	12 Volt
Capacity	110 Ah - 850 A
Alternator	95 A
Reverse gear alarm	Standard
Cabling compliant with regulations	IP 67 - DIN 40050



TRANSMISSION

Hydrostatic with electronic power regulation and closed circuit with variable displacement pump and motor. 3 driving modes: Automotive, Eco and Smart Forward Motion*. 2-speed mechanical gearbox with synchronizer (gear change from standstill).

2 Work Speeds	Forward	Reverse
1 st gear km/h	0 ÷ 6	0 ÷ 6
2 nd gear km/h	0 ÷ 13	0 ÷ 13

2 Transfer Speeds	Forward	Reverse
1 st gear km/h	0 ÷ 18	0 ÷ 18
2 nd gear km/h	0 ÷ 40**	0 ÷ 40**

* Optional, on request. ** Self-limited maximum speed



AXLES

Heavy Duty axles of the same size with epicyclic final reduction gears on each wheel. Rigid front axle. Oscillating rear axle with 25° travel. Distribution of the movement to the two front and rear axles by means of cardan shafts. Automatic self-locking differential on the front axle (optional on the rear)



BRAKING SYSTEM

Service brake: hydraulic multi-disc oil bath on the front and rear axles.
Parking brake: negative hydraulic, electrically operated, on the front axle.



TIRES

Standard	15.5 x 25
----------	------------------



STEERING SYSTEM

Power assisted steering by LOAD SENSING power steering.

Steering angle	80°
Tire inner turning radius	mm 2.703
Tire outer turning radius	mm 4.756
Bucket outer turning radius*	mm 5.270

* in transfer position



HYDRAULIC SYSTEM

Comprising two gear pumps, the first for the loader and steering circuit with LOAD SENSING valve, the second for the fan circuit, having a double rotation speed.

Modular 2-section distributor with general valve.
Double acting jacks. Hydraulic oil cooling radiator.
Full-flow filter on the return circuit.

Single lever servo control for 4-position lifting control and 3-position bucket control.

Max flow rate	lt/1' 105
Flow rate with high-flow kit (optional)	lt/1' 130
Loader calibration pressure	bar 250
Steering calibration pressure	bar 175
Lifting jacks	mm 85x827
Bucket jacks	mm 100x380
Lifting time (full)	sec. 5.1
Lowering time (empty)	sec. 3.1
Unloading time	sec. 1.2
Total cycle time	sec. 9.4



FLUIDS & LUBRICANTS

Engine	lt 8
Front differential	lt 9,2
Rear differential	lt 9,1
Reduction gear/adaptor	lt 1,8
Hydraulic circuit	lt 128
Brake circuit	lt 0,9
Fuel	lt 140
Water radiator	lt 20
AdBlue	lt 20



TECHNICAL FEATURES

Standard bucket capacity	m³ 1,4
Bucket width	mm 2.250
Static tipping load on a horizontal surface	kg 5.600
Static tipping load turned 40°	kg 5.000
Hydraulic lifting capacity at max. height	kg 5.600
Hinge pin height	mm 3.615 (3.565)*
Dump height at 40°	mm 2.890 (2.840)*
Dump distance at 40°	mm 845 (895)*
Breakout force	kg 9.100

* (...) With optional 405/70 R24 tires



DIMENSIONS & WEIGHTS

Max length in transfer position	mm 5.900
Max. width in transfer position	mm 2.250
Tire outer width	mm 2.117
Tread width	mm 1.710
Pitch	mm 2.560
Clear span	mm 280 (230)*
Max height	mm 2.938 (2.888)*
Standard operating weight	kg 7.860 (7.600)*
Maximum permissible weight	kg 8.750

* (...) With optional 405/70 R24 tires

dB NOISE LEVEL

Noise level inside cabin ISO 6396 - LpA	dB(A) 69
External noise level ISO 6395 - LwA	dB(A) 101

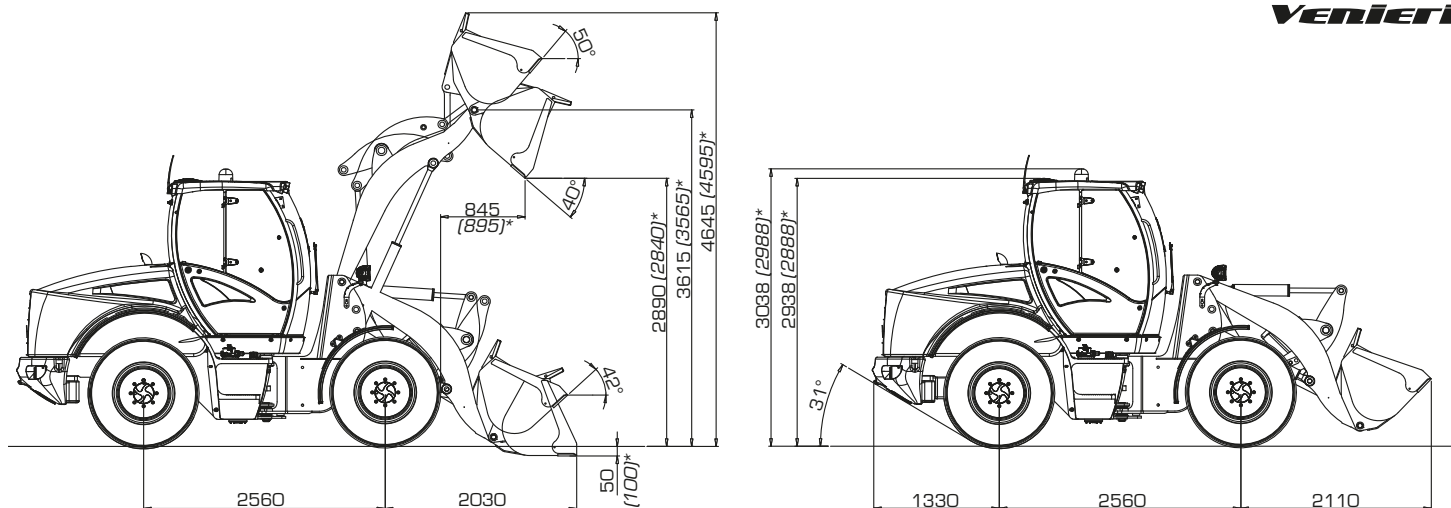

*[...] With optional 405/70 R24 tires

PERFORMANCE DATA



STANDARD MULTIPURPOSE OVERSIZE FORKS

Heaped Bucket Capacity (SAE)	m ³	1,4	1,1	2,0	/
Bucket width	mm	2.250	2.250	2.500	/
Bucket weight	kg	500	600	600	/
Max operating height	mm	4.645 (4.595)*	4.560 (4.510)*	4.560 (4.510)*	/
Fork length (standard)					1000
Fork length (optional)					1200
Hinge pin height	mm	3.615 (3.565)*	3.615 (3.565)*	3.615 (3.565)*	/
Dump angle	°	40°	40°	40°	/
Dump height	mm	2.890 (2.840)*	2.940 (2.890)*	2.840 (2.790)*	/
Dump distance	mm	845 (895)*	795 (715)*	885 (805)*	/
Static tipping load on a horizontal surface	kg	5.600	5.700	5.400	/
Static tipping load - mach. turned	kg	5.000	5.100	4.800	/
Fork tipping load - mach. turned	kg				3.750
Operating load EN 474-3 (80%) [•]	kg				3.000
Operating load EN 474-3 (60%) [•]	kg				2.250
Breakout force	kg	9.100	10.100	8.600	/
Max length in transfer position	mm	5.900	5.845	5.995	/
Bucket outer turning radius	mm	5.270	5.245	5.405	/
Standard operating weight	kg	7.860 (7.600)*	7.760 (7.500)*	7.960 (7.700)*	/

*[...] With optional 405/70 R24 tires [•] Load center at 500 mm

MOST COMMON OPTIONAL TIRES | OTHER TIRES UPON REQUEST



**15,5 R25
MICHELIN XTLA**

L2 tire for multiple uses on different terrains, with excellent traction force.

Machine width:
2.107 mm



**15,5 x 25 CAMSO
LOADMASTER L3**

Tire optimized for all surfaces, with excellent resistance to side impacts and improved stability.

Machine width:
2.127 mm



**405/70 R24
DUNLOP SPT9**

Multi-purpose non-directional, radial tire for industrial and construction applications.

Machine width:
2.217 mm



**455/70 R24
DUNLOP SPT9**

Non-directional, radial tire for construction and industrial applications.

Machine width:
2.212 mm



**440/80 R24
MICHELIN XCML**

Long-life agricultural tire, exceptional traction and load capacity.

Machine width:
2.271 mm



**15,5 R25 NOKIAN
LOADER GRIP 2**

Tire for exceptional traction on soft or frozen ground.

Machine width:
2.104 mm

8.630

PARALLEL KINEMATICS



DIESEL ENGINE

4 in-line cylinders, supercharged, charge air cooling, electronically controlled, common-rail injection, exhaust gas recirculation, water cooling, dry filtration, oxidation catalyst (DOC) particulate filter (DPF) and selective catalytic reduction (SCR). Issued according to EC Directive 97/68 - Stage V/Tier 4f.

Type	Deutz TCD 3.6 L4
Max. power	94,5 kW - 128 HP
Calibration (RPM)	2.300
ISO/TR 14396 power	90 kW - 122 HP
EEC 80/1269 power	90 kW - 122 HP
Maximum torque	Nm 480
Bore	mm 98
Stroke	mm 120
Displacement	cm³ 3.620



ELECTRIC SYSTEM

Battery	12 Volt
Capacity	110 Ah - 850 A
Alternator	95 A
Reverse gear alarm	Standard
Cabling compliant with regulations	IP 67 - DIN 40050



TRANSMISSION

Hydrostatic with electronic power regulation and closed circuit with variable displacement pump and motor. 3 driving modes: Automotive, Eco and Smart Forward Motion*. 2-speed mechanical gearbox with synchronizer (gear change from standstill).

2 Work Speeds	Forward	Reverse
1 st gear km/h	0 ÷ 6	0 ÷ 6
2 nd gear km/h	0 ÷ 13	0 ÷ 13

2 Transfer Speeds	Forward	Reverse
1 st gear km/h	0 ÷ 18	0 ÷ 18
2 nd gear km/h	0 ÷ 40**	0 ÷ 40**

* Optional, on request. ** Self-limited maximum speed



AXLES

Heavy Duty axles of the same size with epicyclic final reduction gears on each wheel. Rigid front axle. Oscillating rear axle with 25° travel. Distribution of the movement to the two front and rear axles by means of cardan shafts. Automatic self-locking differential on the front axle (optional on rear)



BRAKING SYSTEM

Service brake: hydraulic multi-disc oil bath on the front and rear axles.
Parking brake: negative hydraulic, electrically operated, on the front axle



TIRES

Standard	460/70 R24
----------	-------------------



STEERING SYSTEM

Power assisted steering by LOAD SENSING power steering.

Steering angle	80°
Tire inner turning radius	mm 2.590
Tire outer turning radius	mm 4.870
Bucket outer turning radius*	mm 5.350

* in transfer position



HYDRAULIC SYSTEM

Comprising two gear pumps, the first for the loader and steering circuit with LOAD SENSING valve, the second for the fan circuit, having a double rotation speed. Modular 2-section distributor with general valve. Double acting jacks.

Hydraulic oil cooling radiator. Full-flow filter on the return circuit. Single lever servo control for 4-position lifting control and 3-position bucket control.

Max flow rate	lt/1' 105
Flow rate with high-flow kit (optional)	lt/1' 130
Loader calibration pressure	bar 230
Steering calibration pressure	bar 175
Lifting jacks	mm 105x795
Bucket jacks	mm 80x680
Lifting time (full)	sec. 5.4
Lowering time (empty)	sec. 3.9
Unloading time	sec. 1.8
Total cycle time	sec. 11.1



FLUIDS & LUBRICANTS

Engine	lt 8
Front differential	lt 9,2
Rear differential	lt 9,1
Reduction gear/adaptor	lt 1,8
Hydraulic circuit	lt 128
Brake circuit	lt 0,9
Fuel	lt 140
Water radiator	lt 20
AdBlue	lt 20



TECHNICAL FEATURES

Standard bucket capacity	m³ 1,2
Bucket width	mm 2.250
Static tipping load on a horizontal surface	kg 5.150
Static tipping load turned 40°	kg 4.600
Hydraulic lifting capacity at max. height	kg 10.000
Hinge pin height	mm 3.775
Dump height at 40°	mm 2.970
Dump distance at 40°	mm 1.055
Breakout force	kg 9.400



DIMENSIONS & WEIGHTS

Max length in transfer position	mm 6.180
Max. width in transfer position	mm 2.250
Tire outer width	mm 2.230
Tread width	mm 1.770
Pitch	mm 2.560
Clear span	mm 250
Max height	mm 2.890
Standard operating weight	kg 8.200
Maximum permissible weight	kg 8.750

dB NOISE LEVEL

Noise level inside cabin ISO 6396 - LpA	dB(A) 69
External noise level ISO 6395 - LwA	dB(A) 101

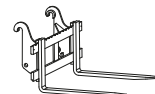
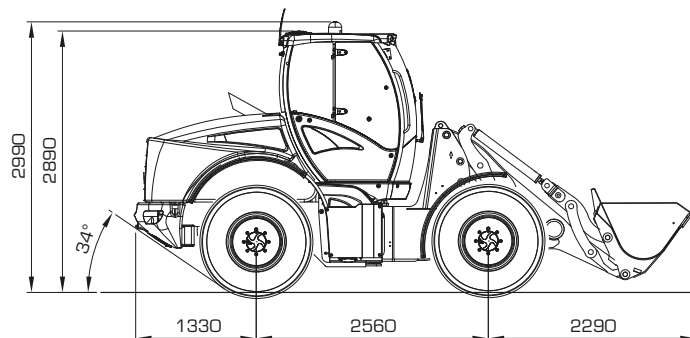
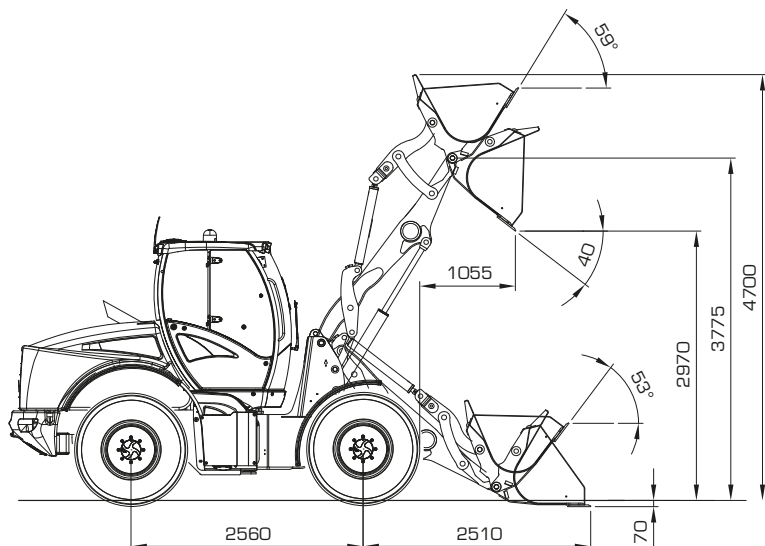

i PERFORMANCE DATA

STANDARD

MULTIPURPOSE

OVERSIZE

FORKS

Heaped Bucket Capacity (SAE)	m ³	1,2	1,1	2,0	/
Bucket width	mm	2.250	2.350	2.500	/
Bucket weight	kg	450	550	600	/
Max operating height	mm	4.700	4.615	4.615	/
Fork length (standard)					1000
Fork length (optional)					1200
Hinge pin height	mm	3.775	3.775	3.775	/
Dump angle	°	40°	40°	40°	/
Dump height	mm	2.970	3020	2.920	/
Dump distance	mm	1.055	1.005	1.095	/
Static tipping load on a horizontal surface	kg	5.150	5.050	4.950	/
Static tipping load - mach. turned	kg	4.600	4.500	4.400	/
Fork tipping load - mach. turned	kg				3.500
Operating load EN 474-3 (80%) [•]	kg				2.800
Operating load EN 474-3 (60%) [•]	kg				2.100
Breakout force	kg	9.400	10.400	8.900	/
Max length in transfer position	mm	6.180	6.125	6.275	/
Bucket outer turning radius	mm	5.350	5.325	5.485	/
Standard operating weight	kg	8.200	8.300	8.350	/

[•] Load center at 500 mm

+ MOST COMMON OPTIONAL TIRES | OTHER TIRES UPON REQUEST



**15,5 x 25
MITAS EM60**

L3 tire suitable for heavy use with excellent self-cleaning properties.

Machine width:
2.104 mm



**405/70 MITAS
EM01 o MPT21**

Not directional multi-purpose tire.

Machine width:
2.117 mm



**440/80 R24
MICHELIN XCML**

Agricultural tire long duration with high traction and high load capacity.

Machine width:
2.211 mm



**500/70 R24
ALLIANCE A580**

Tire with an exclusive profile which guarantees strong traction, specific for soft surfaces.

Machine width:
2.275 mm

9.63D

Z KINEMATICS



DIESEL ENGINE

4 in-line cylinders, supercharged, charge air cooling, electronically controlled, common-rail injection, exhaust gas recirculation, water cooling, dry filtration, oxidation catalyst (DOC) particulate filter (DPF) and selective catalytic reduction (SCR). Issued according to EC Directive 97/68 - Stage V/Tier 4f.

Type	Deutz TCD 3.6 L4
Max. power	105 kW - 143 HP
Calibration (RPM)	2.300
ISO/TR 14396 power	100 kW - 136 HP
EEC 80/1269 power	100 kW - 136 HP
Maximum torque	Nm 500
Bore	mm 98
Stroke	mm 120
Displacement	cm³ 3.620



ELECTRIC SYSTEM

Battery	12 Volt
Capacity	110 Ah - 850 A
Alternator	95 A
Reverse gear alarm	Standard
Cabling compliant with regulations	IP 67 - DIN 40050



TRANSMISSION

Hydrostatic with electronic power regulation and closed circuit with variable displacement pump and motor.

4 driving modes: Automotive, Work, Eco and Smart Forward Motion*. 2-speed mechanical gearbox with mechanical speed ratio variation (Shift On Fly).

2 Work Speeds	Forward	Reverse
1 st gear km/h	0 ÷ 6	0 ÷ 6
2 nd gear km/h	0 ÷ 16	0 ÷ 16

2 Transfer Speeds	Forward	Reverse
1 st gear km/h	0 ÷ 14	0 ÷ 14
2 nd gear km/h	0 ÷ 40**	0 ÷ 40**

* Optional, on request. ** Self-limited maximum speed



AXLES

Heavy Duty axles of the same size with epicyclic final reduction gears on each wheel. Rigid front axle. Oscillating rear axle with 25° travel.

Distribution of the movement to the two front and rear axles by means of cardan shafts. Automatic self-locking differential on the front axle (optional on the rear).



BRAKING SYSTEM

Service brake: hydraulic multi-disc oil bath on the front and rear axles.

Parking brake: negative hydraulic, electrically operated, on the front axle.



TIRES

Standard	17.5 x 25
----------	------------------



STEERING SYSTEM

Power assisted steering by LOAD SENSING power steering.

Steering angle	80°
Tire inner turning radius	mm 2.733
Tire outer turning radius	mm 4.908
Bucket outer turning radius*	mm 5.406

* in transfer position



HYDRAULIC SYSTEM

Comprising two gear pumps, the first for the loader and steering circuit with LOAD SENSING valve, the second for the fan circuit, having a double rotation speed Modular 2-section distributor with general valve.

Double acting jacks. Hydraulic oil cooling radiator.

Full-flow filter on the return circuit.

Single lever servo control for 4-position lifting control and 3-position bucket control.

Max flow rate	lt/1'	155
Loader calibration pressure	bar	230
Steering calibration pressure	bar	175
Lifting jacks	mm	100x815
Bucket jacks	mm	120x380
Lifting time (full)	sec.	4.6
Lowering time (empty)	sec.	3.5
Unloading time	sec.	1.8
Total cycle time	sec.	9.9



FLUIDS & LUBRICANTS

Engine	lt	8
Front differential	lt	17,6
Rear differential	lt	11,9
Reduction gear/adaptor	lt	1,8
Hydraulic circuit	lt	128
Brake circuit	lt	1,1
Fuel	lt	155
Water radiator	lt	20
AdBlue	lt	20



TECHNICAL FEATURES

Standard bucket capacity	m³	1,8
Bucket width	mm	2.350
Static tipping load on a horizontal surface	kg	6.200
Static tipping load turned 40°	kg	5.500
Hydraulic lifting capacity at max. height	kg	6.900
Hinge pin height	mm	3.700
Dump height at 40°	mm	2.900
Dump distance at 40°	mm	815
Breakout force	kg	8.600



DIMENSIONS & WEIGHTS

Max length in transfer position	mm	6.100
Max. width in transfer position	mm	2.350
Tire outer width	mm	2.195
Tread width	mm	1.750
Pitch	mm	2.635
Clear span	mm	380
Max height	mm	2.980
Standard operating weight	kg	9.000
Maximum permissible weight	kg	10.110

dB NOISE LEVEL

Noise level inside cabin ISO 6396 - LpA	dB(A)	69
External noise level ISO 6395 - LwA	dB(A)	99

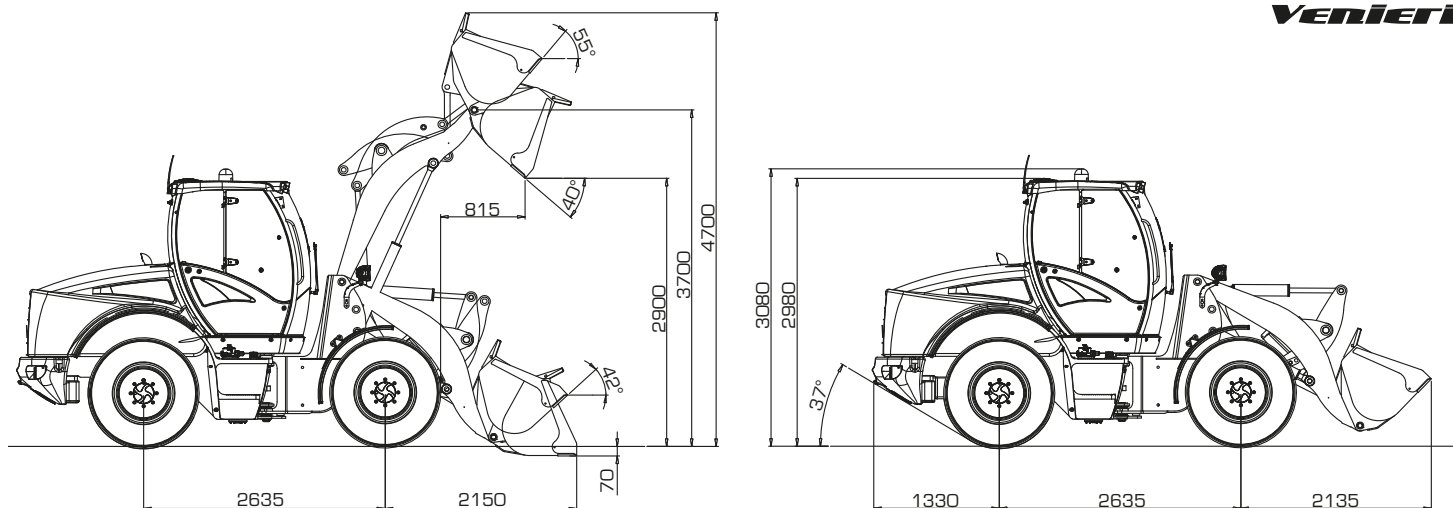

i PERFORMANCE DATA



STANDARD MULTIPURPOSE OVERSIZE FORKS

Heaped Bucket Capacity (SAE)	m ³	1,8	1,3	2,2	/
Bucket width	mm	2.350	2.350	2.500	/
Bucket weight	kg	650	750	750	/
Max operating height	mm	4.700	4.646	4.796	/
Fork length (standard)					1000
Fork length (optional)					1300
Hinge pin height	mm	3.700	3.700	3700	/
Dump angle	°	40°	40°	40°	/
Dump height	mm	2.900	2.950	2.833	/
Dump distance	mm	815	800	924	/
Static tipping load on a horizontal surface	kg	6.200	6.300	6.000	/
Static tipping load - mach. turned	kg	5.500	5.600	5.300	/
Fork tipping load - mach. turned	kg				4.600
Operating load EN 474-3 (80%) [•]	kg				3.680
Operating load EN 474-3 (60%) [•]	kg				2.760
Breakout force	kg	8.600	9.600	7.800	/
Max length in transfer position	mm	6.100	6.045	6.175	/
Bucket outer turning radius	mm	5.406	5.381	5.531	/
Standard operating weight	kg	9.000	9100	9.100	/

[•] Load center at 500 mm

0+ MOST COMMON OPTIONAL TIRES | OTHER TIRES UPON REQUEST



500/70 R24 MICHELIN XCML

Long-life agricultural tire with high traction and high load capacity.

Machine width:
2.351 mm



15,5 R25 MICHELIN XTLA

High traction multi-purpose L2 tire.

Machine width:
2.209 mm



15,5 x 25 CAMSCO LOADMASTER L3

Optimized for multi-surface; high resistance to lateral impact and improved stability.

Machine width:
2.127 mm



17,5 R25 AEOLUS A2233 L5

L5 tire with compound resistant to cut and impact. Very low puncture risk. Tread designed for exceptional traction and stability.

Machine width:
2.205 mm



17,5 R25 MICHELIN XMINE D2 L5

Ideal tire for heavy loads, high strength and excellent traction/adhesion compromise.

Machine width:
2.240 mm



17,5 R25 NOKIAN GRS

All-season tire, ideal for winter conditions. Good driving comfort.

Machine width:
2.198 mm

10.63D

PARALLEL KINEMATICS



DIESEL ENGINE

4 in-line cylinders, supercharged, charge air cooling, electronically controlled, common-rail injection, exhaust gas recirculation, water cooling, dry filtration, oxidation catalyst (DOC) particulate filter (DPF) and selective catalytic reduction (SCR). Issued according to EC Directive 97/68 - Stage V/ Tier 4f.

Type	Deutz TCD 3.6 L4
Max. power	105 kW - 143 HP
Calibration (RPM)	2.300
ISO/TR 14396 power	100 kW - 136 HP
EEC 80/1269 power	100 kW - 136 HP
Maximum torque	Nm 500
Bore	mm 98
Stroke	mm 120
Displacement	cm³ 3.620



ELECTRIC SYSTEM

Battery	12 Volt
Capacity	110 Ah - 850 A
Alternator	95 A
Reverse gear alarm	Standard
Cabling compliant with regulations	IP 67 - DIN 40050



TRANSMISSION

Hydrostatic with electronic power regulation and closed circuit with variable displacement pump and motor.

4 driving modes: Automotive, Work, Eco and Smart Forward Motion*. 2-speed mechanical gearbox with mechanical speed ratio variation (Shift On Fly).

2 Work Speeds	Forward	Reverse
1 st gear km/h	0 ÷ 6	0 ÷ 6
2 nd gear km/h	0 ÷ 16	0 ÷ 16

2 Transfer Speeds	Forward	Reverse
1 st gear km/h	0 ÷ 14	0 ÷ 14
2 nd gear km/h	0 ÷ 40**	0 ÷ 40**

* Optional, on request. ** Self-limited maximum speed



AXLES

Heavy Duty axles of the same size with epicyclic final reduction gears on each wheel. Rigid front axle.

Oscillating rear axle with 25° travel.

Distribution of the movement to the two front and rear axles by means of cardan shafts. Automatic self-locking differential on the front axle (optional on the rear).



BRAKING SYSTEM

Service brake: hydraulic multi-disc oil bath on the front and rear axles.

Parking brake: negative hydraulic, electrically operated, on the front axle.



TIRES

Standard	17.5 x 25
----------	------------------



STEERING SYSTEM

Power assisted steering by LOAD SENSING power steering.

Steering angle	80°
Tire inner turning radius	mm 2.733
Tire outer turning radius	mm 4.908
Bucket outer turning radius*	mm 5.600

* in transfer position



HYDRAULIC SYSTEM

Comprising two gear pumps, the first for the loader and steering circuit with LOAD SENSING valve, the second for the fan circuit, having a double rotation speed.

Modular 2-section distributor with general valve. Double acting jacks. Hydraulic oil cooling radiator. Full-flow filter on the return circuit.

Single lever servo control for 4-position lifting control and 3-position bucket control.

Max flow rate	lt/1'	155
Loader calibration pressure	bar	230
Steering calibration pressure	bar	175
Lifting jacks	mm	105x770
Bucket jacks	mm	80x680
Lifting time (full)	sec.	4.6
Lowering time (empty)	sec.	3.5
Unloading time	sec.	1.8
Total cycle time	sec.	9.9



FLUIDS & LUBRICANTS

Engine	lt	8
Front differential	lt	17,6
Rear differential	lt	11,9
Reduction gear/adaptor	lt	1,8
Hydraulic circuit	lt	128
Brake circuit	lt	1,1
Fuel	lt	155
Water radiator	lt	20
AdBlue	lt	20



TECHNICAL FEATURES

Standard bucket capacity	m³	1,8
Bucket width	mm	2.350
Static tipping load on a horizontal surface	kg	5.800
Static tipping load turned 40°	kg	5.200
Hydraulic lifting capacity at max. height	kg	9.900
Hinge pin height	mm	3.800
Dump height at 40°	mm	2.850
Dump distance at 40°	mm	1.100
Breakout force	kg	8.000



DIMENSIONS & WEIGHTS

Max length in transfer position	mm	6.230
Max. width in transfer position	mm	2.350
Tire outer width	mm	2.195
Tread width	mm	1.750
Pitch	mm	2.635
Clear span	mm	380
Max height	mm	2.980
Standard operating weight	kg	9.500
Maximum permissible weight	kg	10.110

dB NOISE LEVEL

Noise level inside cabin ISO 6396 – LpA	dB(A)	69
External noise level ISO 6395 - LwA	dB(A)	99

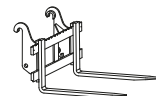
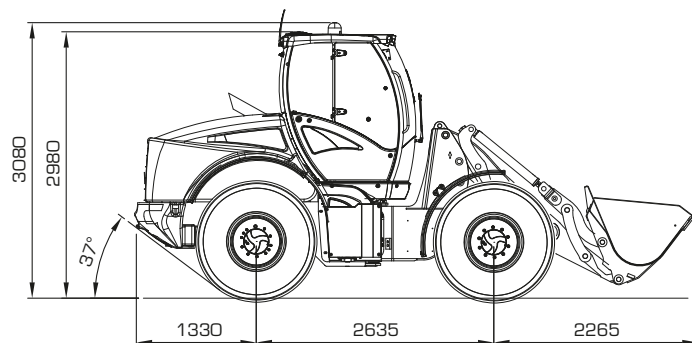
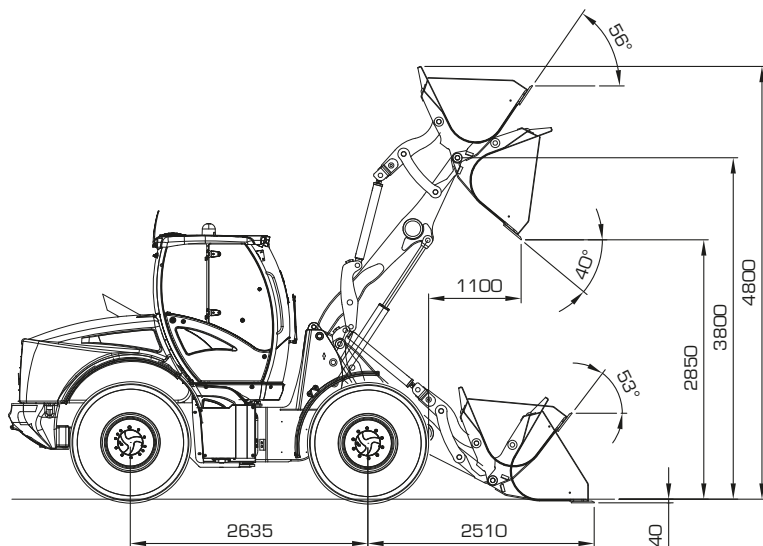

PERFORMANCE DATA

		STANDARD	MULTIPURPOSE	OVERSIZE	FORKS
Heaped Bucket Capacity (SAE)	m ³	1,8	1,3	2,2	/
Bucket width	mm	2.350	2.350	2.500	/
Bucket weight	kg	650	750	750	/
Max operating height	mm	4.800	4.854	4.925	/
Fork length (standard)					1000
Fork length (optional)					1300
Hinge pin height	mm	3.800	3.800	3.800	/
Dump angle	°	40°	40°	40°	/
Dump height	mm	2.850	2.900	2.857	/
Dump distance	mm	1.100	1.085	1.093	/
Static tipping load on a horizontal surface	kg	5.800	5.900	5.600	/
Static tipping load - mach. turned	kg	5.200	5.300	4.900	/
Fork tipping load - mach. turned	kg				4.200
Operating load EN 474-3 (80%) [•]	kg				3.400
Operating load EN 474-3 (60%) [•]	kg				2.500
Breakout force	kg	8.000	9.000	8.076	/
Max length in transfer position	mm	6.230	6.175	6.305	/
Bucket outer turning radius	mm	5.600	5.575	5.726	/
Standard operating weight	kg	6.500	9.600	9.600	/

[•] Load center at 500 mm

MOST COMMON OPTIONAL TIRES | OTHER TIRES UPON REQUEST



**17,5 x 25
MITAS EM60**



**500/70 R24
MICHELIN XCML**



**15,5 R25
MICHELIN XTLA**



**15,5 x 25 CAMSO
LOADMASTER L3**



**17,5 R25 AEOLUS
A2233 L5**



**17,5 R25 MICHELIN
XMINE D2 L5**



**17,5 R25
NOKIAN GRS**

Tread designed for heavy duty use on construction sites and combined conditions. Excellent self-cleaning properties.

Machine width:
2.195 mm

Long-life agricultural tire with high traction and high load capacity.

Machine width:
2.351 mm

High traction multi-purpose L2 tire.

Machine width:
2.209 mm

Tire optimized for multi-surface use; high resistance to lateral impact and improved stability.

Machine width:
2.127 mm

L5 tire, cut- and impact-resistant compound. Minimal puncture risk. Tread designed for exceptional traction and stability.

Machine width:
2.205 mm

Ideal tire for heavy loads, high strength and excellent traction/adhesion compromise.

Machine width:
2.240 mm

All-season tire, ideal for winter conditions. Good driving comfort.

Machine width:
2.198 mm