

**BB** : Pulverizador de hormigón con corte de refuerzo.  
(dientes y filos cortantes intercambiables)

	BRINCAR	F1	F2	F3	L*			
kg	~	mm	mm	mm	tt	mm	t	
CON 2000	2010	2250	700	450	240	98	73	500
CON 2700	2740	2450	850	560	285	125	99	570

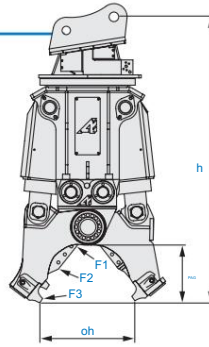

**BF** : Combinación de hormigón y acero  
(dientes y filos cortantes reemplazables).

	BRINCAR	F1	F2	F3	L*			
kg	~	mm	mm	mm	t	mm		
CON 2000	2030	2410	710	500	345	130	70	260
CON 2700	2840	2630	800	580	375	133	85	300

  

	LLAMAR	IPN	BIEN		
mm	mm	mm	mm	mm	mm
CON 2000	300	240	180	10	50
CON 2700	360	360	220	10	60

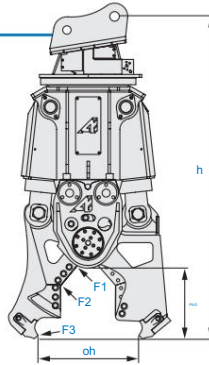

**BR** : para cortar vías de ferrocarril  
(filos de corte intercambiables).

	BRINCAR	F1	F2	F3	L*		
kg	~	mm	mm	mm	tt	mm	t
CON 2000	2040	2100	170	200	210		

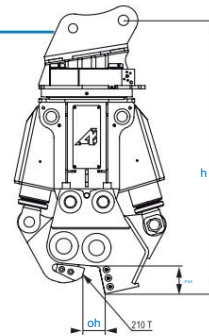

**CF** : Tijeras de desecho  
(filos de corte intercambiables).

	BRINCAR	F1	F2	F3	L*			
kg	~	mm	mm	mm	tt	mm	t	
CON 2000	2030	2350	385	410	340	132	87	280
CON 2700	2840	2580	450	500	402	206	105	310

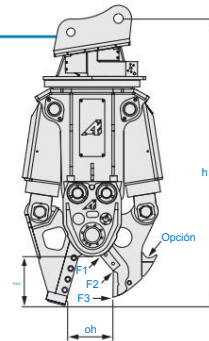

	LLAMAR	IPN	BIEN		
mm	mm	mm	mm	mm	mm
CON 2000	300	240	180	10	50
CON 2700	360	300	220	10	60

	con sin Válvula Gesch	Ciclo con/sin Válvula Gesch	360°	
	bar l/min	segundo	bar l/min	t
CON 2000	380 200/300	4/4	140 18/28	18/27
CON 2700	380 300/420	4/4	140 28/40	26/37

Peso sin placa de montaje  
Opción :  
Válvula de velocidad = + 60 kg  
L\* = ancho de la mandíbula

- 1 Placa de montaje atornillada.
- 2 Rotación hidráulica 360°.
- 3 2 cilindros invertidos, completos protegido.
- 4 Carcasa fabricada en acero HLE.
- 5 Sistema de cambio rápido patentado para reemplazar las mordazas (cambiar en aprox. 20 minutos.).
- 6 Cada mandíbula intercambiable está incluida. Se entrega con su propio stand.



CB : Betonschere  
(dientes y filos cortantes reemplazables).



BRINCAR F1 F2 F3 L\*

kg ~ mm mm mm tt mm t

CON 2000 1980 2320 710 470 345 120 84 120

CON 2700 2640 2480 810 560 410 140 102 120

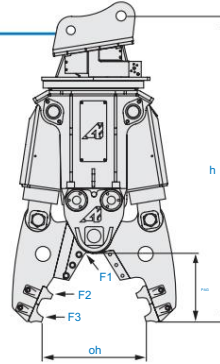

BV : sólo para CU27000 – para cortar  
Placas y techos  
(dientes y filos cortantes reemplazables).



BRINCAR F1 F2 F3 L\*

kg ~ mm mm mm tt mm t

CON 2000 2150 2370 520 570 210 102 76 560

CON 2700 2840 2560 600 600 320 140 88 610

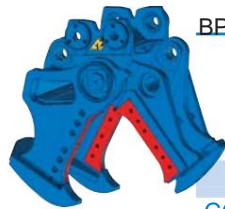
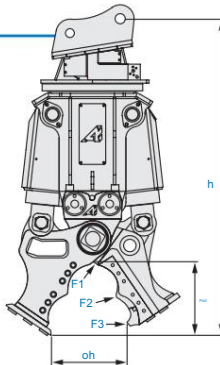

BP : para cortar vigas de acero y  
Travesas de ferrocarril antes del reciclaje  
(dientes reemplazables. Corte de refuerzo).



BRINCAR F1 F2 F3 L\*

kg ~ mm mm mm tt mm t

CON 2700 2870 2570 600 610 267 127 75 550

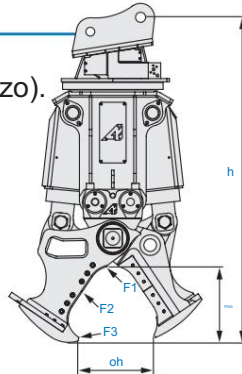

GR : para cortar tanques metálicos,  
Cubas y bandejas de espesor medio.



SALTO F1 F2 F3 L\*

kg ~ mm mm mm tt mm mm

CON 2000 2050 2200 210 290 220 - 108 320 16

CON 2700 2840 2400 250 330 315 - 142 320 25

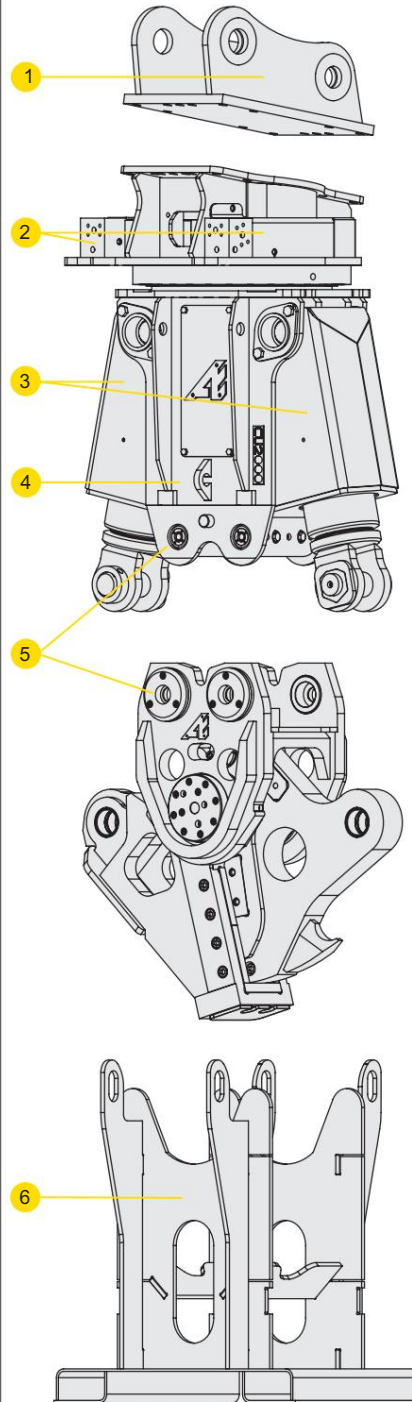
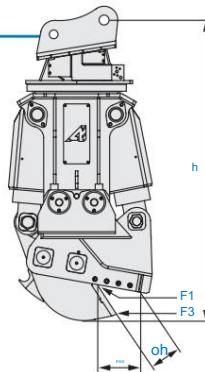

¡PELIGRO!

Para cantidad de aceite Kiefer GR  
Regular 155 litros/minuto.