



XE530E

CRAWLER EXCAVATOR



SOLID TO SUCCEED



Operating weight 54500kg

Bucket capacity 2.45m³

Rated power 321kW

XCMG European Sales and Services GmbH

Europark Fichtenhain B4, 47807 Krefeld, Germany

Email : info@xcmg-ess.de



WWW.XCMGGLOBAL.COM
XCMG OFFICIAL WEBSITE



SOLID TO SUCCEED

Applications : Marble mines, non-ferrous metal mines, infrastructure projects, large earthworks.

Features : Adopting PIC feedforward intelligent control and independent cooling system, with high efficiency, high reliability and low fuel consumption. The new large-displacement main pump is energy-saving under light load. The independent cooling system can adapt to high-cold and high-temperature environments. The widened undercarriage has good stability.

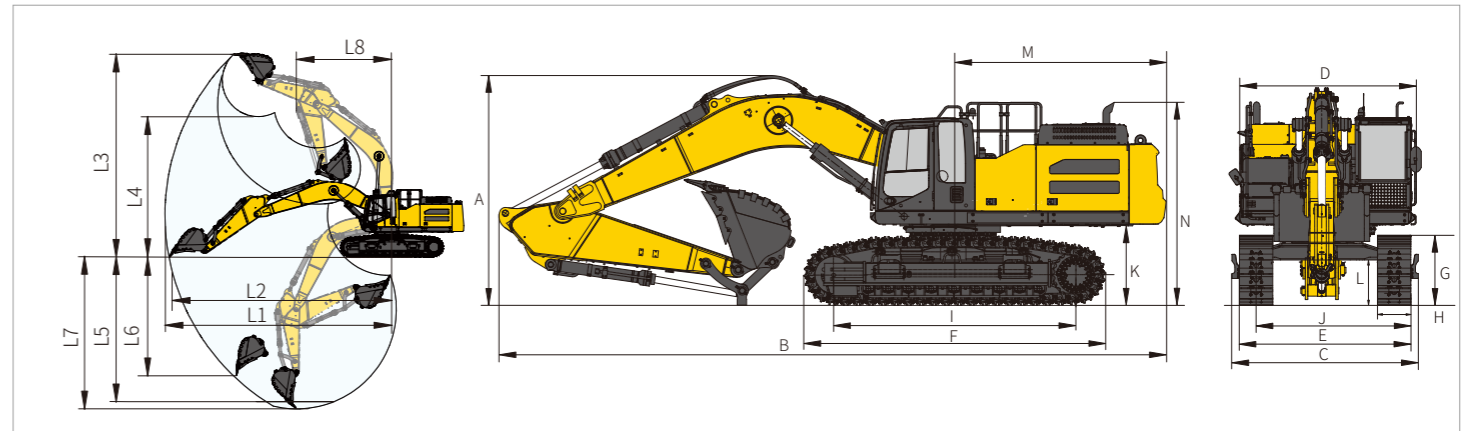

Item contents	Unit	Parameters
Working range		
L1 Maximum reach	mm	11946
L2 Maximum reach at GRP	mm	11717
L3 Maximum digging height	mm	10837
L4 Maximum unloading height	mm	7533
L5 8 ft. level floor digging depth	mm	7706
L6 Maximum vertical digging depth	mm	4721
L7 Maximum digging depth	mm	7970
L8 Minimum swing radius	mm	5024

Item contents	Unit	Parameters
Dimensions		
A Overall height	mm	4300
B Overall length	mm	12029
C Overall width	mm	3495
D Upper structure width	mm	2995
E Chassis width (extended/retracted)	mm	3495/2995
F Track length	mm	5470
G Track height	mm	1231
H Standard track shoe width	mm	600
I Track wheelbase	mm	4407
J Track gauge (extended/retracted)	mm	2890/2390
K Counterweight ground clearance	mm	1422
L Minimum ground clearance	mm	754.5
M Tail Swing Radius	mm	3953
N Hood height	mm	3265

Never attempt to lift or hold any load in excess of the rated lifting capacity at the specified lifting radius and height. The lifting point is located on the lifting eye of the arm (Bucket weight is not included), any additional attachment such as bucket should be deducted from the lifting weight. When determining the net lifting weight allowed for the machine, the weight of the slings and any auxiliary lifting devices must be deducted from the rated lifting capacity. Lifting capacity is based on the machine standing on firm and level ground. The operator should consider working conditions such as soft or uneven ground. Before operating the machine, the operator should familiarize himself with the safety procedures in the relevant manual.

		kg											Dozer Blade up		
		In travel direction					Against travel direction					Right angle to travel direction			
LD	Y	3.0m		4.5m		6.0m		7.5m		9.0m		MAX		m	
		3.35m	Z2			*18910	*18910	*14520	*14520	*10720	*10720	*10730	9870	*8850	8540
	Z1			*20970	*20970	*16710	*16450	*13540	12160	*11760	9470	*9240	8140	10.00	
	Z3	*18120	*18120	*19670	*19670	*15340	*15340	*14170	11420	*12260	9050	*11810	8760	9.20	

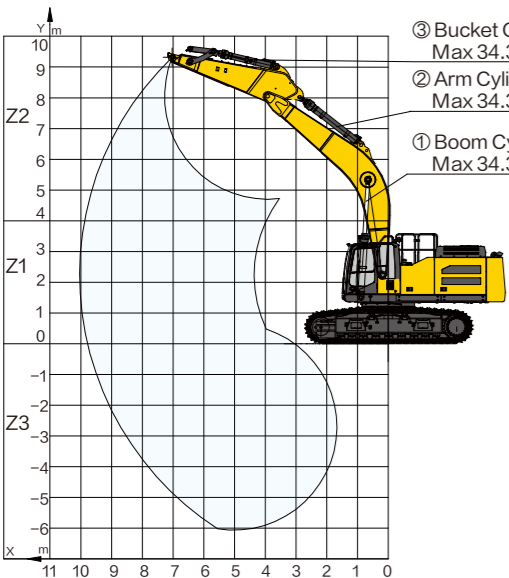

Note 1 The lifting capacities in the table refer to the case where no external thrust intervention is included.
 Note 2 Lifting capacities marked with an asterisk (*) in the table are limited by hydraulic capacity and should not exceed 75% of the minimum tipping load or 87% of the hydraulic capacity.
 Note 3 The least stable position is on the side of the excavator.
 Note 4 The lifting capacity table applies only to machines originally built and normally assembled by the manufacturer.
 Note 5 The machine is rated for an operating weight of 54500 kg (120151 lb), which includes 0.6 m (1.97 ft) steel tracks, a 6.9 m (22.6 ft) boom, a 3.35 m (11.0 ft) arm, a 10300 kg (22707 lb) counterweight, all working fluids, and a 75 kg (165 lb) operator, exclusive of the bucket.
 Note 6 Lifting capacity shall be in accordance with ISO 10567:2007.
 Note 7 For all configurations of track specifications, the lifting capacity is kept within ± 5%.

Item contents	Unit	Parameters
Operating weight	kg	54500
Engine		
Engine brand/model	-	Cummins/X12
Rated power/rpm	kW/rpm	321/1800
Direct injection	-	√
Electric injection	-	√
4-stroke	-	√
Water-cooled	-	√
Turbocharged	-	√
Air-to-Air intercooling	-	√
Stroke	mm	144
Cylinder bore	mm	132
Number of cylinders	-	6
Maximum torque/rpm	Nm/rpm	2034/1400
Displacement	L	11.8

Main performance		
Travel speed (high/low)	km/h	5.4/3.2
Swing speed	r/min	8.4
Maximum swing torque	kN-m	180
Gradeability	-	35° (70%)
Ground specific pressure	kPa	92.5
Bucket digging force (ISO)	kN	276
Arm digging force (ISO)	kN	215
Maximum traction force	kN	358

Track		
Standard track shoe width	mm	600
Number of track shoes (per side)	-	50
Number of track roller (per side)	-	9
Number of track carrier roller (per side)	-	3

Item contents	Unit	Parameters
Hydraulic system		
Main pump	-	Two variable pumps
Pilot pump	-	Constant-displacement pump
Heat dissipation pump	-	One variable pump
Maximum flow rate of main system	L/min	384
Main system pressure	MPa	34.3
Main system pressure (power-max pressure)	MPa	37
Pilot system pressure	MPa	3.9
Heat dissipation pump pressure	MPa	28
Travel system pressure	MPa	34.3
Swing system pressure	MPa	28.5

Oil capacity		
Fuel tank capacity	L	650
DEF tank capacity	L	85
Hydraulic oil tank capacity	L	430

Cab standard		
ISO 10262: 1998 (OPG)	-	√

Standard		
Length of boom	mm	6900
Length of arm	mm	3350
Bucket capacity	m ³	2.45 (Root bucket)

Optional		
Length of boom	mm	-
Length of arm	mm	-
Bucket capacity	m ³	2.52 (Reinforced bucket) 3.1 (Earthmoving bucket)