

All Rights Reserved  
Materials and specifications are subject to change without notice.  
Featured machines in photos may include additional equipment. See your XCMG dealer for available options.



Hydraulic Excavators  
**XE220EN**



**XCMG European Sales and Services GmbH**  
Address: Europark Fichtenhain B 4,47807 Krefeld, Deutschland  
Tel: +49 (0) 2151 8206 890  
Fax: +49 (0) 2151 8206 899  
E-Mail: [info@xcmg-ess.de](mailto:info@xcmg-ess.de)

**XUZHOU CONSTRUCTION MACHINERY GROUP IMP. & EXP. CO., LTD**  
Address: No.1, Tuolanshan Road, Xuzhou Economic Developing Zone, Jiangsu, China 221004  
Tel: + 86(0) 516 8773 9703  
Fax: + 86(0) 516 8773 9230  
E-Mail: [europe@xcmg.com](mailto:europe@xcmg.com)

[www.xcmg.com](http://www.xcmg.com)

Rated Power: 129 kW  
Operating Weight: 23400 kg  
Standard Bucket Capacity: 1.05 m<sup>3</sup>





The XCMG XE220EN Stage V builds further on its reputation as one of the most sold and appreciated excavators for XCMG. The further development resulted in a product that is more fuel efficient on the one side and more productive at another side.

If you are looking to get your work done with a durable brand, you can trust XCMG and look no further than our XE220EN.



► **RELIABILITY:**

Even under the harshest conditions, XCMG has made its aim to build long-life products. XCMG has already a long relationship with the best component suppliers in the world. Cummins engines, Kawasaki KPM hydraulic pumps, main control valve and swing motor, and high quality travel motors guarantee you the best performance. Oversized cylinders in combination with long-life reinforced pins, and polymer shims and bushings ensure best performance with unchanged durability.

► **PRODUCTIVITY AND EFFICIENCY:**

Strong and unmatched bucket and arm digging forces give the XE220EN the ability to fulfill various work, and improve productivity and efficiency.

► **SAFETY SOLUTIONS:**

A rear camera, a right camera and large side mirrors, powerful LED lighting, anti-slip steps and platforms. Guard rails for safe access to the upper structure. The ROPS (Roll Over Protective Structure) and the OPG (Operator Protective Guard) cabin ensure the operator's safety.

► **VERSATILITY:**

Multiple boom and arm sizes together with special configurations are available to efficiently carry out any task your business requires.

► **EASY-TO-USE ATTACHMENTS:**

Programmable auxiliary lines AUX1 (single and dual way) and AUX2 are provided to support your hydraulic attachments like, grabs, shear, hammer and many more.

► **COMFORTABILITY:**

To ensure operator comfort, we offer a spacious cab with low noise and vibration levels and excellent all-round visibility. Fully adjustable heated air suspension seat and air conditioning with climate control as standard.

► **CONTROLLABILITY:**

7 work and 3 power modes, proportional control with a user-friendly 8" TFT LCD color monitor.

► **STRONG POWER:**

The Cummins B6.7 stage V/Tier 4 Final engine is exceptionally powerful - with high torque at low revs. This makes maximum flow is already available at low rpms with a fuel-efficient engine regime.

► **ADVANCED FILTRATION:**

Easily accessible highly efficient filters and cleaners that remove all contaminations from your jobsite and protect your investment in the best possible way.

► **SIMPLE AND EASY MAINTENANCE:**

Easy access to all compartments. Maintenance data and signs are directly available from monitor.

► **UNDERCARRIAGE DURABILITY:**

The CAE-designed X-shape undercarriage enables even weight distribution, increasing stability and durability, and prevents damage from rocks and debris.



# Excellent Performance and Fuel Economy

## ► Power without compromise

The XE220EN makes handling your task efficient and comfortable.

- The optimized Kawasaki-KPM hydraulic system makes sure that all that engine power is used in the best possible way by delivering accurate maximum pumping in a smooth way.
- All that power has reliably increased digging power, the lifting capacities, and the traction force.
- Greater fuel efficiency means you can keep costs down and reduce environmental impact.



### POWER MATCH TECHNOLOGY

The XE220EN is equipped with a Cummins B6.7 engine. Famous for its excellent fuel efficiency, reliability, and long service intervals, it combines exceptional power output and high torque at low revs.

Selective Catalytic Reduction (SCR) technology - combined with a Diesel Particulate Filter (DPF) - ensures compliance with Stage V regulations.

If the engine is the heart of the excavator, the XICS (XCMG Intelligent Control System) is its brain - providing a perfectly synchronized communication link between the engine's ECU (Electronic Control Unit) and the hydraulic system. The CANBUS (Controller Area Network) system enables a constant flow of information between engine and hydraulic system, so that power is delivered exactly as needed.

### FUEL ECONOMY TECHNOLOGY

- A choice between 3 power modes and 7 attachment modes guarantees optimum performance under all conditions.
- Electronic control of fuel consumption.
- The auto-idle function reduces the engine speed when the controls are inactive for a preselected amount of time or when the safety lever is switched off. The engine will immediately return to its original selected speed when the operator touches the controls.
- For optimum cooling, the fan speed is controlled by a viscous clutch that results in lower fan noise with better fuel efficiency

### Easy hydraulic maintenance:

- 2000/4000 hours of hydraulic oil replacement (depending on the hydraulic oil type)
- Replace the hydraulic oil return filter after 500 hours
- Replacement of the hydraulic oil suction filter element after 2000 hours

### Less engine service:

- 500 hours engine diesel filter replacement
- 500 hours engine oil and filter replacement
- The long service intervals guarantee limited downtime.

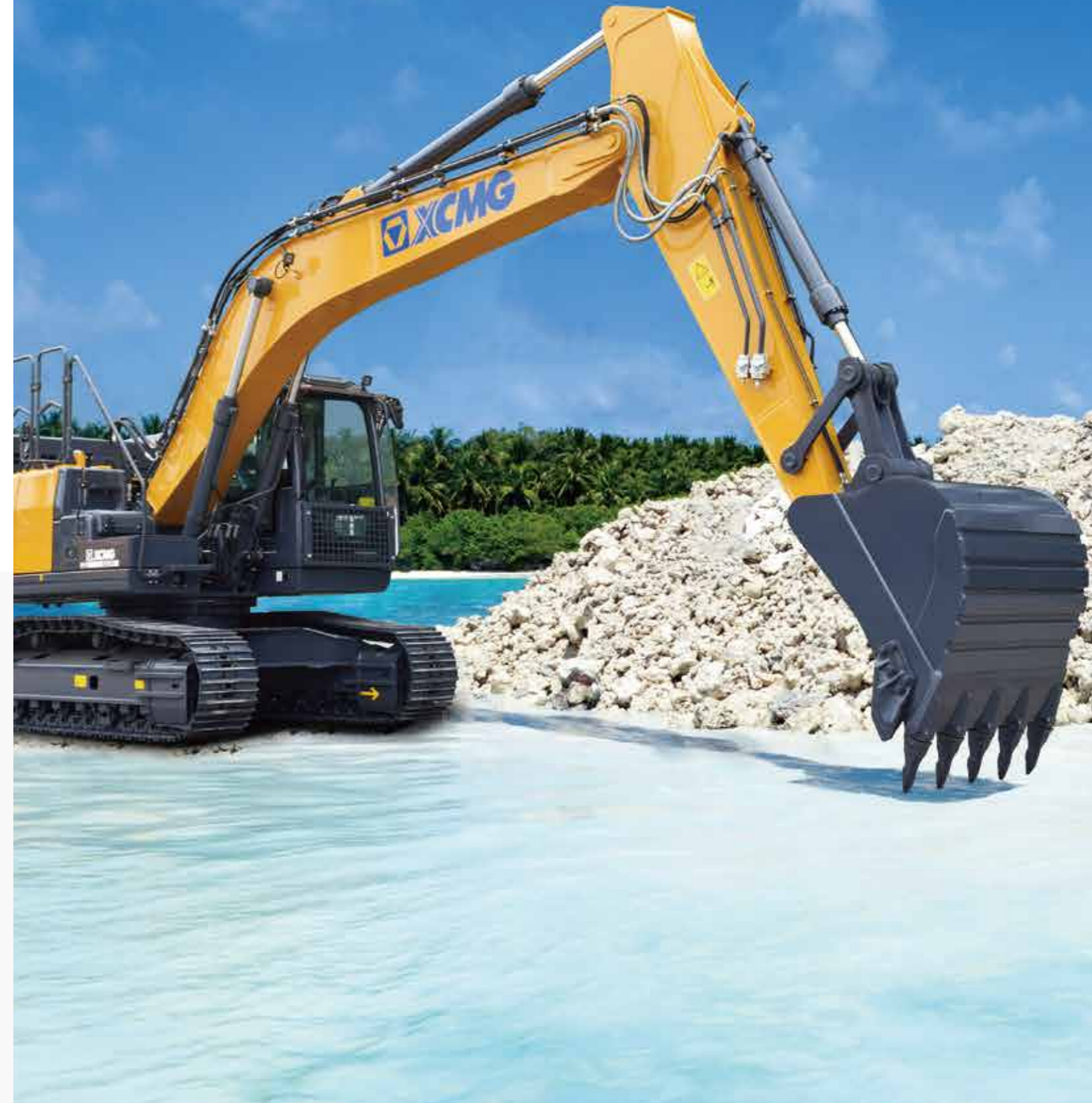



# First Choice for Comfort

The XE220EN cabin is designed to support increased productivity with a spacious comfortable operator environment. The pressurized cab is ISO-certified for your safety and offers a comfortable heated fully adjustable air-suspension seat with several storage compartments and a clear all-round view of your jobsite. The reduced noise and vibration levels with automatic air-conditioning/climate-control will make your workday more easy and comfortable.



### POWER

An industry-leading Cummins engine that saves on fuel and meets the Stage V/Tier 4 F emission regulations powers the XCMG XE220EN.

### Advanced control technology

Ergonomic, advanced, and simple-to-operate - Kawasaki's proportional joystick delivers ultra-precise and smooth control over all movements. The orientation of the joystick's rollers and buttons is adjustable.

### Air conditioning with automatic climate control

A choice from 5 different working modes to regulate the airflow and to adjust the system's air temperature maintains the optimal desired temperature. A recirculated air function is also available.

### Bluetooth radio as standard and DAB radio as option

Standard Bluetooth FM radio. Optionally, we now also offer a radio with DAB function.

### Storage space

The new cab has 7 storage compartments - including a hot/cool box, a storage box for magazine/papers, and a cup holder.

### Cab suspension

Even at the roughest applications where you are working, the cab's improved new suspension system dampens and smoothens out unwanted feedback from your jobsite.

### Quick coupler control

A standard quick coupler hydraulic system with pipelines lets you exchange your attachment easily from the operator's seat. It facilitates the most common systems.

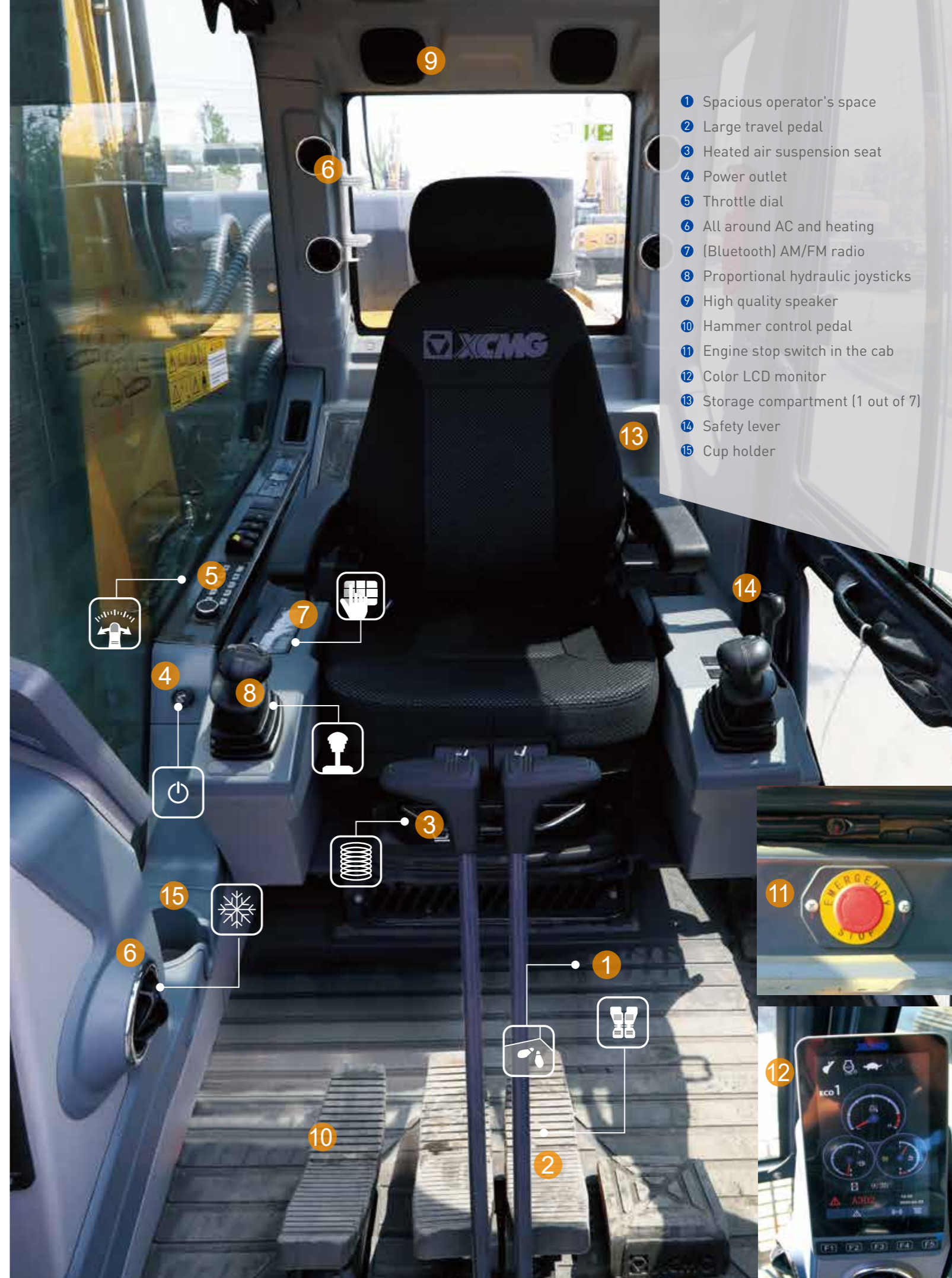

- 1 Spacious operator's space
- 2 Large travel pedal
- 3 Heated air suspension seat
- 4 Power outlet
- 5 Throttle dial
- 6 All around AC and heating
- 7 (Bluetooth) AM/FM radio
- 8 Proportional hydraulic joysticks
- 9 High quality speaker
- 10 Hammer control pedal
- 11 Engine stop switch in the cab
- 12 Color LCD monitor
- 13 Storage compartment (1 out of 7)
- 14 Safety lever
- 15 Cup holder

## Machine interfaces

All machine interfaces – including joysticks, keypad, panel and larger LCD monitor – are ergonomically designed for optimum control and efficiency, resulting in increased productivity and workplace wellbeing. The switches have been simplified and climate control is now integrated into the keypad for easy adjustments.

- The new multi-function 8" TFT LCD monitor displays a comprehensive range of useful technical information, allowing you to check the machine's status and settings at a glance.
- Highly sensitive and low-effort joysticks and clear convenient controls enable you to work smooth and safely with minimum effort for increased comfort and efficiency.
- The new adjustable proportional auxiliary functions support precise and smooth control of your attachments.

### Intelligent monitor

The upgraded 8" TFT monitor features a day and night display with full user access to the machine settings and maintenance data. Any abnormality is clearly displayed on the screen, allowing you to work safely and confident with an accurate overview of all conditions.

- |                        |                                    |
|------------------------|------------------------------------|
| 1. Work mode           | 2. Auto idle                       |
| 3. Travel speed (H/L)  | 4. Power boost                     |
| 5. Pre-heat indication | 6. Quick coupler operation warning |
| 7. Coolant temperature | 8. AdBlue level                    |
| 9. Hour meter          | 10. Time and date                  |
| 11. Menu button        | 12. Mute button                    |
| 13. Engine fault       | 14. Fault information query        |
| 15. Fault code area    | 16. Fuel level                     |
| 17. Power mode         |                                    |

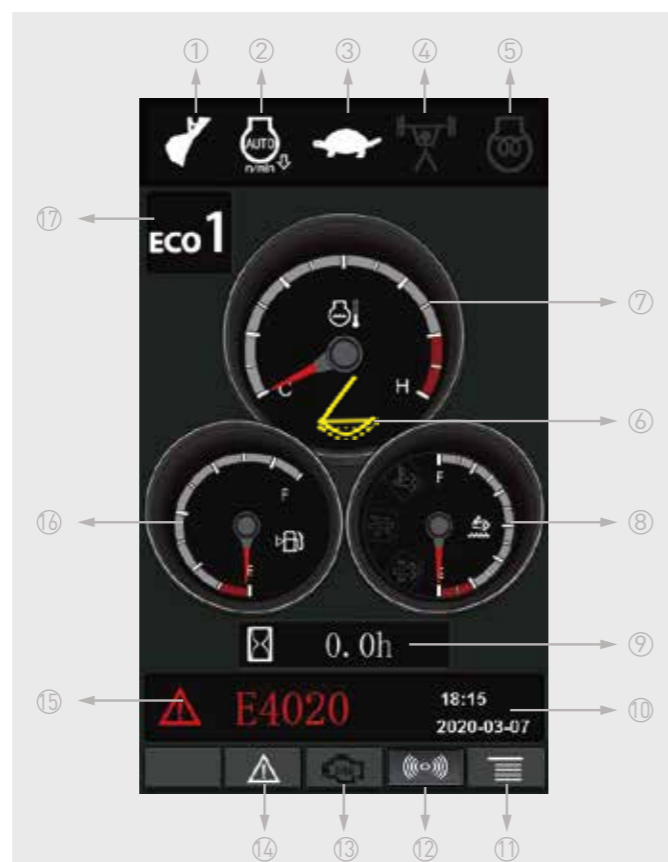

### Dynamic power management

- Activating the power boost control system increases the digging force by 8.8 %
- Auto-idling starts 4 seconds after all controls are returned to the neutral position.

### 7 work modes and 3 power modes

Deliver the needed power according to your special application while minimizing fuel consumption:

- N: Normal mode,
- H: Heavy-duty mode,
- S: Standard mode,
- Eco: Economy mode,
- T: High altitude mode,
- ATT1: Breaker/hammer mode,
- ATT2: Shear mode,
- ATT3: Thumb plier mode,
- ATT4/5: Auxiliary modes.



Air cleaner



Pre-cleaner

Air cleaner: air filter life and engine efficiency are directly related to the amount of debris ingested through the engine's air intake. Therefore, the pre-cleaner (as standard) is the first stage of an air intake system that prevents the majority of heavier-than-air particles from entering.

## ► Designed for long-term robustness and safety

XCMG has developed one of the most rigorous strength and reliability testing procedures, The XCMG E-series features durability under the most extreme conditions and is therefore one of the most popular brands in its home market.

We continually manufacture the most durable machines in order to reduce the cost of ownership. The robust upper frame, undercarriage structure, and front attachments show their real value in tough working conditions and guarantee higher productivity.

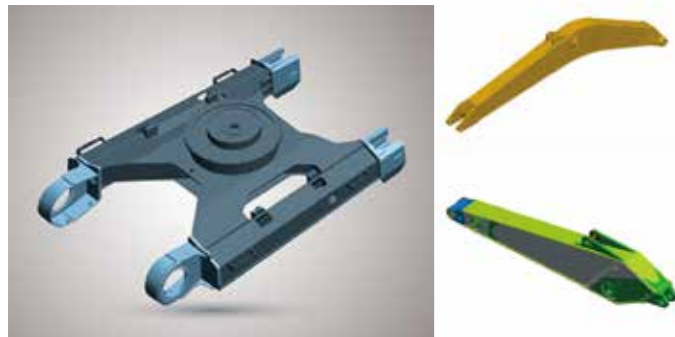

### Reinforced durability of the X-chassis

The X-shaped undercarriage has a higher durability than demanded on the jobsite, as proven through numerous tests including road tests and virtual simulation.

### Undercarriage durability with easy maintenance

- The chain is composed of sealed, self-lubricating links for long-term performance
- Long life track tensioners and the idlers
- Heavy-duty wear resistant cast sprockets
- Durable lubricated track rollers

### Strengthened boom and arm

FEA has been used to calculate the best load distribution throughout the machine structure. For better protection of the base of the arm, reinforced bars have been added. The arm structure has been strengthened for the roughest conditions.

### Hi-grade (high-pressure) hoses

The E-series uses a new type of high-pressure hoses with improved heat and pressure resistance to increase the durability of the machine.

### Reinforced pin, bush, and polymer shim

The new series improved the lubricity of the connecting parts between the machine and attachments. Gaps with attachments are minimized by wear-resistant long-life pins, bushes, and polymer shims, supporting the highest performance with invariable durability.

## ► Excellent serviceability

Our machines are designed for simple routine maintenance, while skilled XCMG technicians are available to provide extra support if needed. To get the most out of your machine, choose the package you need from a broad range of service agreements. Uptime, productivity and residual value are all maximized, making the XE220EN an economical and rewarding choice.



### Simple and easy maintenance

- A large guard rails are installed along with anti-slip steps and plates, for safer and easier access to the whole upper structure
- The cab's air-conditioning filter is lockable and placed on the cab's side for easy access
- A battery cut-off switch to easily disconnect the battery for jobsite-required safety measures
- Shut-off valves on the pre-filter piping line and the fuel tank drain piping make servicing easier and prevents pollution from leakage
- The engine parts can be reached easily via the top and side panels
- For extra accessibility and servicing convenience, all filters (engine oil filter, fuel pre-filter, fuel filter and hydraulic pilot filter) are located in the pump compartment.

### Pre-start monitoring system

The XE220EN has a pre-start monitoring system that shows you coolant temperature, hydraulic oil temperature, engine oil pressure, fuel levels, and the AdBlue® level. It will also indicate fluid and filter intervals to keep the machine in top performing condition.

### Proactive maintenance solutions

- Extended warranty: extended warranty covering parts, travel, and labor
- Routine maintenance: your dealer will support you with routine service at regular intervals
- Genuine parts: manufactured and tested to ensure long lifetime of your machine.

### SCR tank and easy diesel tank filling

The ECU (Engine Control Unit) monitors with sensors of the AdBlue® system and warns the operator for potential system malfunctions. A fuel filler pump, an on-board pump system, lets you fill your fuel tank quickly from an external source (like a fuel drum) – the system stops automatically when the fuel tank is full or the fuel source is empty.

### Centralized lubrication greasing points

To make maintenance easier.

## ■ Engine

Designed to deliver superior performance and fuel efficiency, the Cummins Stage IV diesel engine fully meets the emissions regulations. To optimize machine performance, the engine uses high-pressure fuel injectors, an air-to-air inter-cooler, and electronic engine controls. 4-cycle water-cooled, turbocharged, Exhaust Gas Recirculation (EGR) and Selective Catalytic Reduction (SCR) with no Diesel Particulate Filter (DPF).

XE220EN	
Model	Cummins QSB6.7
No. of cylinders	6
Rated power at 2100 rpm	
(SAE J1995)	129 kW (173 hp) at 2200 rpm
(SAE J1349)	114 kW (153 hp)
(ISO 9249)	114 kW (153 hp)
Max. torque at 1500 rpm	89.9 kgf.m (881 Nm)
Idle (low - high)	700 - 1200 rpm
Piston displacement	408 in <sup>3</sup>
Bore × stroke	107 mm × 124 mm
Starter	24 V × 7.8 kW
Batteries - Alternator	2 × 12 V, 150 Ah - 24 V, 70 A
Air filter	Donaldson's the latest PSD air filter and pre-filtered dust separator

## ■ Undercarriage

Extremely robust construction throughout - made of high-quality, durable materials, with all welded structures designed to limit stresses.

- Lifetime lubricated track rollers, idlers and sprockets fitted with floating seals
- Track shoes made of induction-hardened alloy with triple grouser
- Heat-treated connecting pins
- Hydraulic track adjuster with shock-absorbing tension mechanism

### • Number of rollers and track shoes per side

XE220EN	
Upper rollers (standard shoe)	2
Lower rollers	9
Number of links & shoes per side	49
Link pitch	190
Overall track length	4455

## ■ Weight

	Shoe width (mm)	Operating weight (t)	Ground pressure (kgf/cm <sup>2</sup> )
Triple grouser	500 (Std.)	23400	58.4

## ■ Hydraulic system

The XICS (XCMG Intelligent Control System) is the brain of the excavator - minimizing fuel consumption and enabling the efficiency of the hydraulic system to be optimized for all working conditions. To harmonize the operation of the engine and the hydraulics, the XICS is connected to the engine's electronic control unit (ECU) via a data transfer link.

- The hydraulic system enables independent and combined operations - 2-speed travel offers either increased torque or high travel speed
- A cross-sensing pump system and an auto-deceleration system improve fuel efficiency.
- 7 work modes, 3 power modes - flow and pressure control of auxiliary hydraulic circuits from control panel
- Computer-controlled pump flow control

### • Pumps flow & system pressure

XE220EN	
Main pumps, type:	2 × variable displacement tandem axial
Maximum flow at 1750 rpm	2 × 218 l/min
Pilot pump, type:	Gear pump
Maximum flow at 1750 rpm	27 l/min
Relief valve settings:	
Pressure up	34.3/37 kg/cm <sup>2</sup>
Travel	32.3 kg/cm <sup>2</sup>
Swing	27.5 kg/cm <sup>2</sup>
Pilot	3.9 kg/cm <sup>2</sup>

## ■ Cab

Optimal climate control is provided by the integrated air-conditioning and heating system. An automatically- controlled fan supplies the pressurized and filtered cab air, which is distributed throughout the cab from multiple vents. The fully adjustable heated air suspension operator's seat includes a seat belt. The operator can adjust the ergonomic seat and joystick console separately according to his preferences.

Note - Declared single-number noise emission values are the sum of measured values and the associated uncertainty, and they represent the upper boundaries of the range of values which is likely to occur in measurements.

### • Noise emission

XE220EN	
Noise level LpA (ISO 6396)	71 dB(A)
Noise level LwA (ISO 6395)	103 dB(A)

## ■ Component weights

Item	Unit	XE220EN	Remarks
Upper structure without front	kg	11730	With counterweight
Lower structure assembly	kg	7570	500 mm shoe
Front assembly	kg	4200	Without cylinder
Counterweight	kg	4500	Standard counterweight
Boom	mm/kg	5680/1520	Including bushing
Arm	mm/kg	2400/720	Including bushing
		2910/780	

## ■ Swing mechanism

The swing mechanism uses an axial piston motor, driving a 2-stage planetary reduction gear for maximum torque bathed in oil.

- Swing bearing: single-row, shear-type ball bearing with induction hardened internal gear
- Internal gear and pinion immersed in lubricant

### • Swing speed & torque

XE220EN	
Maximum swing speed	11.5 rpm
Maximum swing torque	69.5 kN.m

## ■ Drive

An independent, high-torque axial piston motor through a planetary reduction gearbox drives each track. Two levers with foot pedals guarantee smooth travel with counter-rotation on demand.

The track frame protects the travel motors with hydraulically released multi-disc brakes and planetary gears.

### • Speed & traction

XE220EN	
Travel speed (low - high)	3.5- 5.4 km/h
Maximum traction	18.8 ton
Maximum gradeability	35° / 70 %

## ■ Fluid capacities

XE220EN	
Fuel tank	300 L
Cooling system (radiator)	23 L
Urea (DEF) tank	42 L
Hydraulic oil tank	200 L
Engine oil	17.5 L
Swing drive	5.3L
Travel device	2×4.2L

## ■ Hydraulic cylinders

High-strength steel piston rods and cylinder bodies. Shock-absorbing (cushion) mechanism fitted in all cylinders for shock-free operation and extended piston life.

Cylinders	Quantity	Bore × rod diameter × stroke (mm)
Boom	2	120 × 85 × 1221
Arm	1	135 × 95 × 1475
Bucket	1	115 × 80 × 1060

## ■ Buckets

Bucket type	Capacity (m <sup>3</sup> ) SAE	Width (mm)		Weight (kg)	Boom 5.68 m	
		With side cutters	W/o side cutters		Arm 2.4 m	Arm 2.9 m
GP	0.4	766	700	425	-	-
	0.5	-	608	656	A	A
	0.6	986	913	651	A	A
	0.75	1076	1003	730	A	A
	1.2	1519	1446	894	A	B
	1.3	1437	1415	955	B	C
HD	0.93	1276	1203	816	A	A
	1.05	1354	1354	959	A	A
	1.2	1325	1280	935	A	B
SD	0.8	960	960	877	A	A
	0.9	1060	1060	925	A	A
	1	1146	1146	965	A	A

### GP: General purpose; HD: Heavy duty; SD: Severe duty;

A: Suitable for materials with a density less than or equal to 2100 kg/m<sup>3</sup>;

B: Suitable for materials with a density less than or equal to 1800 kg/m<sup>3</sup>;

C: Suitable for materials with a density less than or equal to 1500 kg/m<sup>3</sup>;

Based on ISO 10567 and SAE J296, arm length without quick-coupler. For reference only.

## Standard track width: 2550 mm · W/o bucket

Unit: 1000 kg	A		1.5 m		3.0 m		4.5 m		6.0 m		7.5 m		Max. reach		
	B	□	□	□	□	□	□	□	□	□	□	□	□	A	
One-piece boom 5.70 m Arm 2.9 m Shoe 500 mm Counterweight 4.25 t	7.5 m								5	3.5			4.5	3.3	6.14
	6.0 m								5.3	3.5			4.1	2.6	7.28
	4.5 m								5.1	3.3	3.9	2.4	3.6	2.2	7.99
	3.0 m					6.8	4.4		5	3.1	3.8	2.4	3.3	2	8.36
	1.5 m					6.5	4.1	4.8	3	3.7	2.3	2.3	3.2	2	8.44
	0.0 m			9.7	6.1	6.4	3.9	4.7	2.9	3.7	2.2	3.3	2	8.26	
	-1.5 m			9.1	6.2	6.3	3.9	4.6	2.8	3.7	2.2	3.5	2.1	7.78	
	-3.0 m	20.8	13.6	9.9	6.3	6.4	4	4.7	2.9			4	2.5	6.94	
-4.5 m		13.6	10.1	6.5	6.6	4.1					5.3	3.3	5.59		

Unit: 1000 kg	A		1.5 m		3.0 m		4.5 m		6.0 m		7.5 m		Max. reach		
	B	□	□	□	□	□	□	□	□	□	□	□	□	A	
One-piece boom 5.70 m Arm 2.4 m Shoe 500 mm Counterweight 4.25 t	7.5 m								4.5	3.9			5.64		
	6.0 m								5	4.2			4.1	3.1	6.84
	4.5 m								5.3	4.2			3.6	2.6	7.56
	3.0 m					6.8	5.3	5.1	3.9	3.9	2.9	3.3	2.4	7.93	
	1.5 m					6.5	4.9	5	3.7	3.8	2.9	3.2	2.4	8	
	0.0 m			9.7	7.3	6.4	4.7	4.8	3.6	3.7	2.7	3.3	2.4	7.78	
	-1.5 m	20.8	16.4	9.1	7.4	6.3	4.7	4.7	3.6	3.7	2.6	3.5	2.5	7.26	
	-3.0 m		16.4	9.9	7.6	6.4	4.8	4.6	3.3	3.7	2.6	4	3	6.33	
-4.5 m			10.1	7.8	6.6	4.9	4.7	3.5			5.3	3.9	4.78		

□ : Over front  
□ : Over side or 360°

- The lifting capacity is based on the ISO10567 standard.
- \* = The maximum lifting capacity is limited by the hydraulic capacity of the machine.
- The lifting capacity does not exceed 87% of the hydraulic capacity or 75% of the tipping load with the machine on level and firm ground.
- The operator should be familiar with the machines operating- and maintenance manual. Local regulations concerning the safe operation of machinery must be followed at all times.
- The lift diagrams only covers machines that are originally built by XCMG; without lifting chains and any other lifting equipment.
- When the excavator is used to lift or handle materials, it must comply with local regulations.

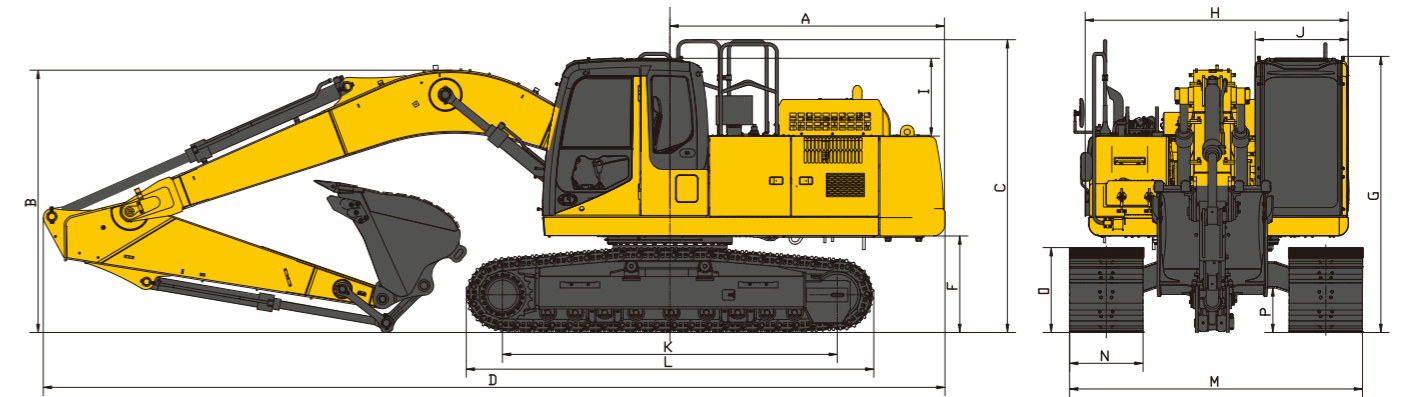

## Dimensions

XE220EN		One-piece boom	
Boom length - mm		5680	
Arm length - mm		2400	2900
Bucket capacity - m³		1.2	1.05
A Tail swing radius - mm	3025		3025
B Shipping height (boom) - mm	3150		3100
C Shipping height (hose) - mm	3188		3188
D Shipping length - mm	9640		9850
E Shipping width - mm	2550		2550
F Counterweight clearance - mm	1053		1053
G Height over cab - mm	2980		2980
H Upper structure width - mm	2540		2540
I Cab height above house - mm			
J Cab width - mm	1020		1020
K Tumbler distance - mm	3850		3650
L Track length - mm	4455		4455
M Undercarriage width - mm	2550		2550
N Shoe width std. - mm	500		500
O Track height - mm	945		945
P Ground clearance - mm	485		485

## Digging forces (ISO)

XE220EN		One-piece boom	
Boom length - mm		5680	
Arm length - mm		2400	2900
Bucket capacity - m³		1.2	1.05
Bucket (Normal/Press. Up) - ton	155		149
Arm (Normal/Press. Up) - ton	121		111

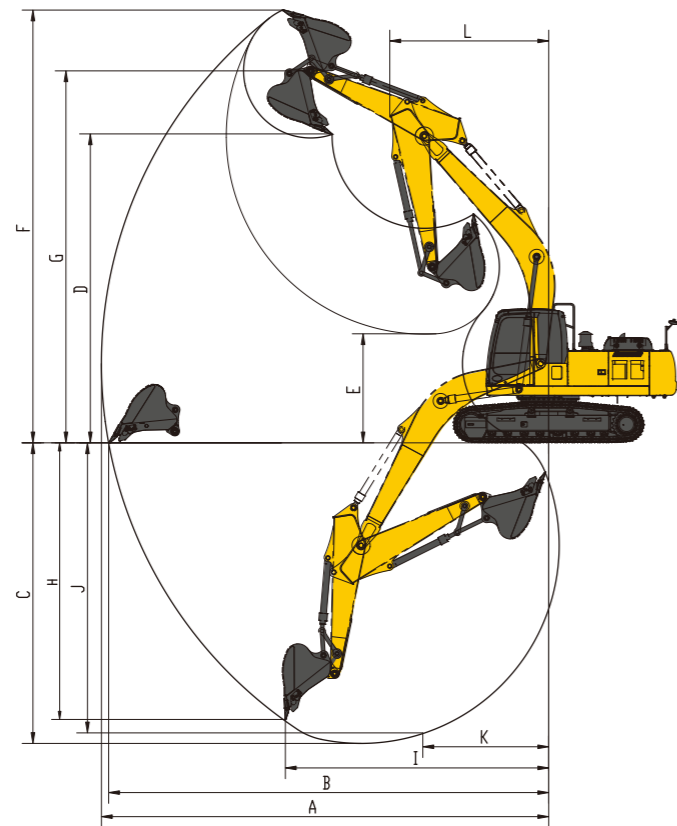

### Working range

XE220EN		One-piece boom	
Boom length - mm		5680	
Arm length - mm		2400	2900
Bucket capacity - m <sup>3</sup>		1.2	1.05
A	Max. digging reach - mm	9430	9940
B	Max. digging reach (ground) - mm	9260	9780
C	Max. digging depth - mm	6170	6680
D	Max. loading height - mm	6650	6780
E	Loading height - mm	2980	2400
F	Max. digging height - mm	9500	9620
G	Max. bucket pin height - mm	8120	8240
H	Max. vertical wall depth - mm	5550	5715
I	Max. radius vertical - mm		
J	Max. digging depth [8° level] - mm	5950	6500
K	Min. radius 8° line - mm		
L	Min. swing radius - mm	3530	3530

### Engine

Urea Tank	●
Automatic preheating	●
Fuel-water separator with water level indication sensor	●
Fuel-water separator with heater [24 V]	○
Axial seal air cleaner	●
50 C high temperature ambient cooling assembly	●
Dust screen for radiator	●
Fuel marker	●
Fuel-water quick release device	●
Electronically controlled silicone oil clutch	●
Fuel filling pump 50 L/min	●
Fuel breather valve	●
Air filter service indicator	●
Auto-idle function	●

### Hydraulic System

Auxiliary hydraulic valve	●
One & two way hydraulic line for hammer and thumb plier	●
Hydraulic quick coupler lines	●
Attachment tilting and rotating lines	●
Hydraulic oil ISO VG 46	●
Hydraulic oil ISO VG 32	○
Hydraulic oil ISO VG 68	○
Right proportional joystick with rocker switch [AUX1]	●
Left proportional joystick with rocker switch [AUX2]	●
Gauge pressure monitoring	●
Hammer circuit oil filter	●

### Cab & Interior

Pressurized cab	●
Air suspension seat with heater	●
Control box	●
Rain visor	●
Front windshield divided 70/30 ratio	●
Double laminated windshield and other toughened windows	●
Sliding fold-in front window	●
Bi-directional air outlet air conditioner with defroster [automatic type] [pressurization function]	●
"Color LCD display capable of displaying warning information, filter / liquid replacement information and working hours"	●
Travel control pedal with detachable manual control lever	●
Double stereo speaker	●
Cup holder	●
Coat hook	●
Floor mat	●
Retractable seat belt [51 mm [2"] wide]	●
High and low travel speed switch	●
One-key boost mode	●
Reserve switch for working aids	○
Sunlight protection, roof	●
Top sunroof	●
Windshield wiper with intermittent feature	●
File packet	●
Hot and cool box	○
Rear window emergency exit	●
Hammer for emergency escape	●

### Undercarriage

2x2 track guard	●
2x49 joint track, 2x9 bottom roller	●
2x47 joint track, 2x8 track roller	○
2x2 top roller	●
Bottom frame traction ring	●
500 mm [19.7"] triple grouser track shoes	●
Protective device kit: undercarriage bottom sealing plate, travel motor sealing plate	●
Track rubber block	○

### Working device

Boom 5.68m	●
Arm 2.91m	●
1.2 m <sup>3</sup> reinforced bucket	○
Arm 2.4m	○
Arm 2.52m	○
Arm 2.7m	○
0.8 m <sup>3</sup> rock bucket	○
1.05 m <sup>3</sup> reinforced bucket	●
0.9 m <sup>3</sup> rock bucket	○
24 inch width ditching bucket	○

### Electronic system

Battery [2x 850 CCA]	●
70 A 24 V DC generator	●
7.8 kW starter motor	●
24 V cigarette lighter	○
12 V cigarette lighter	●
5 V USB interface	●
Engine stop switch in the cab	●
Right-view camera	●
Rear-view camera	●
270° range image	○
AM-FM radio with digital display	●
Travel buzzer with switch	●
Beacon lamp	●
2 LED cab-mounted front lights	●
1 LED cab-mounted rear light	●
2 LED boom-mounted lights	○
12 V power interface	●
Ceiling light	●

### Counterweight

4.5 t counterweight	●
200 kg auxiliary counterweight	○

### Lubrication system

Automatic lubrication system	●
Centralized lubrication greasing points	●

### Safety

Side impact beam	○
Driving door locks and cabin locks	●
Alarm horn	●
Quick coupler switch with buzzer	●
Isolation plate between engine and oil pump chamber	●
Battery circuit breaker	●
Overheat alarm	●
Safety handrails and pedals	●
Anti-skid plate/ anti-skid paste	●
Hydraulic safety locking lever	●
Right and left rear-view mirrors	●
Counterweight rear-view mirrors	●
Safety valves for boom cylinders	○
Safety valve for arm cylinder	○
Roll over protective structure [ROPS]	●
Operator protective guards[OPG]	●
Safety net on the front lower windshield	●

Standard: ●  
Optional: ○

•Some of this standard or optional equipment may not be available for certain markets.  
•Pictures may include attachments and optional equipment that are not available in your area.  
•Materials and specifications are subject to change without advance notice.  
•Please contact your local XCMG dealer for more information on availability or to customize your machine to suit your applications requirements.

# Optimum Services, XCMG Guaranteed



XCMG-approved attachments



Genuine parts



Extension of warranty



Financial solutions



Maintenance contract



Telematics

## Professional Integrated Complete Solutions

The XCMG group has built a strong reputation based on the quality, reliability and durability of its construction machinery. What's more, XCMG has gradually established a service network to constantly provide its local integrated and highly efficient complete solutions for all customers.

## Full Range of Services Ready for you

In order to respond to your needs as fast as possible, XCMG experts are on their way to your job site from one of our facilities near you. A full range of services is available in order to reduce your total cost of ownership and increase your revenue.



XCMG Global Spare parts System



Mobile cranes



Excavators



Aerial work platforms



Wheel loaders



Road machinery

