

XD80



XD80

Vibratory Roller

XD80 dual drive dual vibration vibratory road roller features small amplitude, high frequency vibration, big exciting force as well as independent vibration of front and rear drum.

It is mainly applicable to compaction work on asphalt top layer of newly built pavement and thinner stable soil pavement, and road maintenance work.

With compact structure, high flexibility, small blind area, high operating comfort, it is an ideal compaction equipment for municipal maintenance and highway custody.

Performance and characteristics

- Its unique XCMG series 5 industrial design combines aesthetics and practice.
- Comfort and simple operation system
- Bilateral access, bright color paint, ergonomics design principle;
- Spacious operating platform provides enough space for operator's movement, operator's seat has three-level shock absorption;
- Foldable ROPS meeting the CE directive, providing safety protection under extreme conditions;
- Driving safety and reliability is guaranteed by three means of braking: neutral brake, secondary brake and parking brake.
- Waterproof instrument control panel, simple and intuitive.
- All switch buttons are arranged for clear and intuitive operation.

Main dimensions

Dimensions	L	W	H1	H2	W1	L1	H	S	D
XD80	2250	895	2475	250	800	1550	1580	12	620

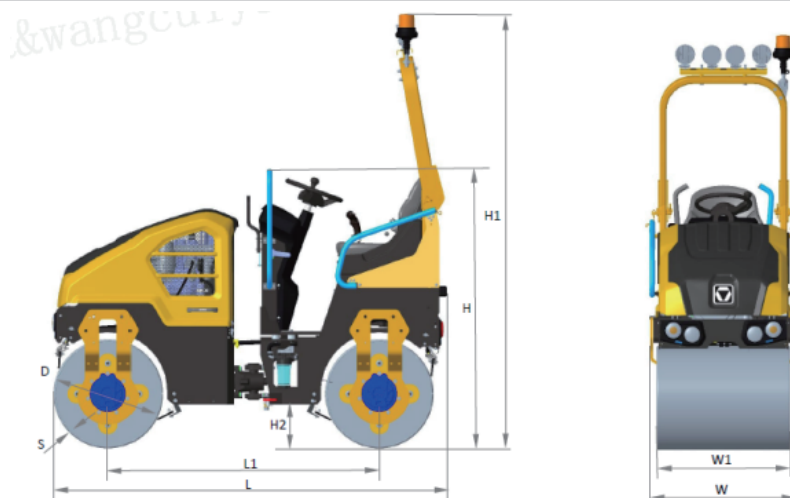

Main specifications

Item	Content	Unit	Value
Weights Parameters	Operating weight	kg	1600
	Front axle weight	kg	750
	Rear axle weight	kg	850
	Static linear load	N/cm	92/104
Driving Parameters	Working speed	km/h	0~10
	Theoretical gradeability	%	30
	Minimum ground clearance	mm	250
	Wheelbase	mm	1550
	Oscillation angle	°	±8
	Steering angle	°	±32
	Braking distance(smooth cement pavement)	m	≤3.4
Compaction Parameters	Vibration frequency	Hz	48/65
	Nominal amplitude	mm	0.4
	Drum diameter	mm	620
	Drum width	mm	800
	Engine	Model	
Type			In-line 3-cylinder water-cooled
Rated power		kW	16.3
Rated speed		r/min	2600