

XD120



XD120

Vibratory Roller

XD120 is suitable for compaction of soil and asphalt pavement in narrow areas such as sidewalks, parking lots and residential roads, it can also be used for compacting thin stable soil layering, which is an ideal compaction equipment for asphalt surface laminating in municipal maintenance and high-speed pipe maintenance.

Performance and characteristics

- 67Hz high frequency vibration, 720mm large diameter drum, quick and efficient compaction.
- 210L large-capacity water tank, interval controlled sprinkling for prolonged operation.
- Small turning radius, high flexibility, wider application range.
- Drum and articulated frame are maintenance-free during the whole life cycle.
- Excellent side visibility, superior control experience.

Main dimensions

Unit: mm

Model	L	L1	W	W1	H	H1	H2	S	D
XD120	2610	1773	1286	1200	1845	2575	275	10	720

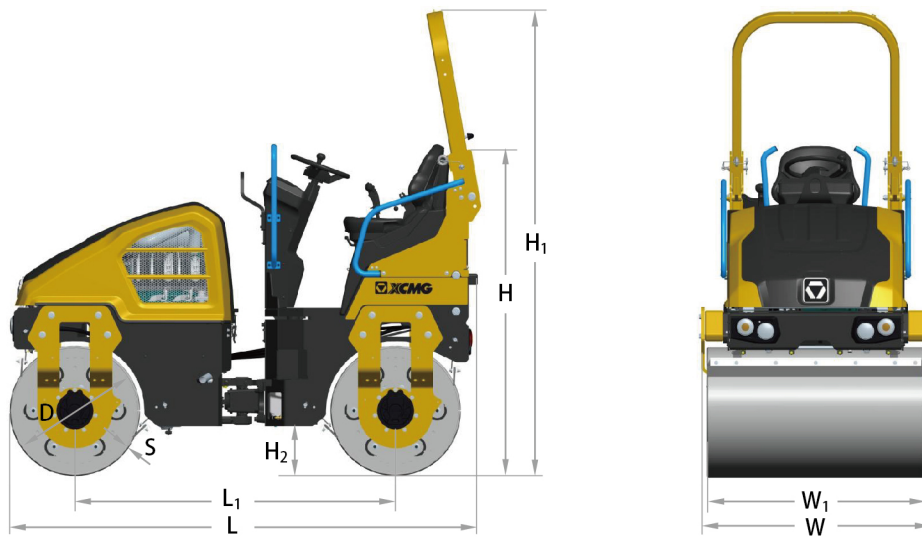

Main specifications

Item	Content	Unit	XD120
Weights	Operating weight	kg	2850
	Maximum operating weight	kg	3450
	Front axle weight	kg	1350
	Rear axle weight	kg	1500
	Static linear load	N/cm	110/122
Maneuverability	Operating speed	km/h	0-10
	Gradeability	%	30
	Minimum turning radius(outer)	mm	3700
	Minimum ground clearance	mm	275
	Wheel base	mm	1773
	Steering angle	°	±32
	Oscillation angle	°	±8
Compaction parameters	Vibration frequency	Hz	63/67
	Nominal amplitude	mm	0.5
	Excitation force	kN	30/39
	Drum diameter	mm	720
	Drum width	mm	1200
Engine	Model	-	D1803
	Emission		EU Stage V/EPA TIER4f
	Rated power	KW	24.6
	Rated speed	r/min	2400
Capacities	Fuel tank	L	35
	Water tank	L	210