

RP905i



RP905i

Paver

RP905i paver is a construction machine mainly used for the paving of surface material on various classified highways. The machine fully absorbs the advanced technologies and advantages of similar international products. It adopts the most advanced technologies in the world today, such as full hydraulic drive, microcomputer control, left and right independent drive, material level sensing control, electronic automatic leveling, vibratory compaction, variable-frequency electric heating, etc. It has the advantages of good paving stability, uniform material supply, high precompaction density, good leveling, comfortable operation, convenient maintenance, energy conservation and environmental protection. All the components of the machine are internationally selected components, strictly tested and reasonably combined, which makes the manufacturing quality and reliability of the whole machine reach the international advanced level, and is the first choice of road construction equipment.

Performance and characteristics

- The left and right driving devices run separately, the microcomputer control is adopted and the constant-speed automatic control technology is utilized to control the paving speed.
- The mature and reliable Cummins B6.7 diesel engine is installed, with the strong power output up to 158kW.
- The three-in-one compound radiator is adopted and the fan speed is adjusted automatically with the water temperature to ensure that the machine can work continuously for long time at a high temperature of 50 °C.
- Four sets of full hydraulic systems that run separately are adopted for the conveying and distributing; the material pad control technology (or ultrasonic) is adopted for conveying, and the ultrasonic sensing control technology is adopted for distributing; the material level is controlled automatically to ensure stable material level in the chute.

Main dimensions

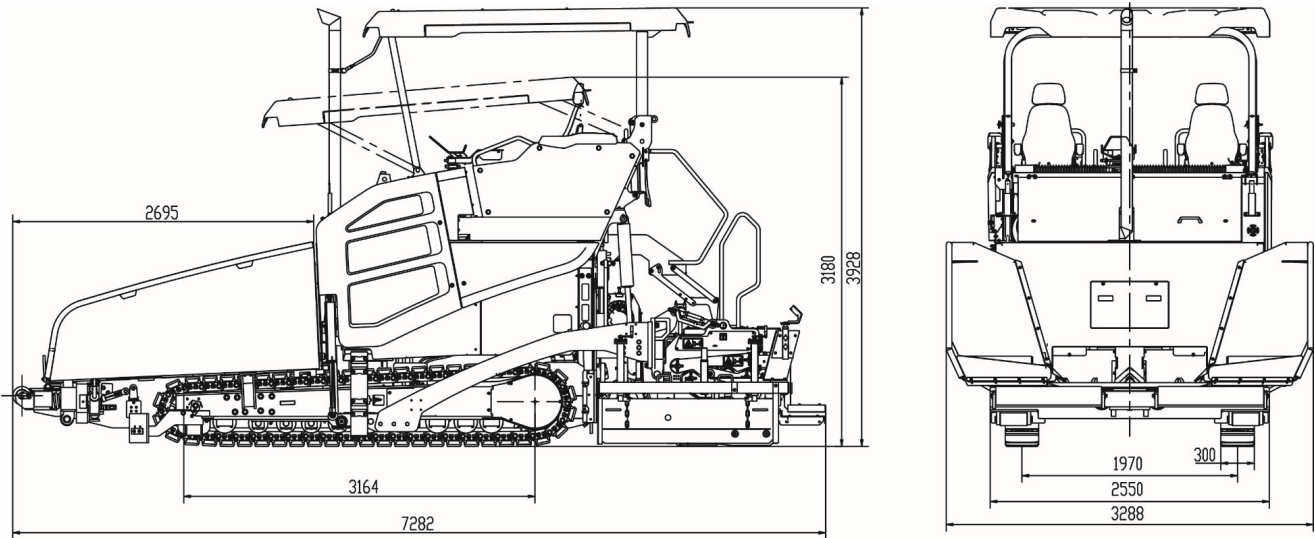

Main specifications

Item	Unit	E500BTV	E600BTV
Basic paving width	m	2.5~5	3.0~6
Maximum paving width	m	8.0	9.0
Maximum paving thickness	mm		450
Maximum operating speed	m/min		25
Maximum traveling speed	km/h		4
Theoretical productivity	t/h		900
Hopper capacity	t		15
Gradeability	%		20
Flatness (standard deviation)**	mm		1.2
Cross slope error	%		±0.2
Arch adjustment range	%		-1.5~+4.5
Diesel engine model	/		B6.7
Rated power of diesel engine	kW		173
Rated speed of diesel engine	r/min		2000
Distributing speed	r/min		0~110
Conveying speed	m/min		0~34
Vibrating speed	r/min		0~1800
Vibrating amplitude	mm		4
Vibration frequency	Hz		0~50
Overall weight	t	22.5~23.8	22.8~24.5
Transportation outline dimensions	mm	6982X2550X3080	6982X3000X3080
Diesel tank capacity	L		240
Hydraulic oil tank capacity	L		260