

# Dynapac CC2300

## Double drum vibratory rollers



### Technical data



#### Masses

Max. operating mass	9400 kg
Operating mass (incl. ROPS)	8500 kg
Operating mass (incl. Cab)	8700 kg
Module mass (front/rear)	4250 kg/4250 kg



#### Traction

Speed range	0 -12 km/h
Vertical oscillation	±7°
Max. theoretical gradeability	39 %



#### Compaction

Split drums	Yes
Centrifugal force (high/low amplitude)	72 kN/59 kN
Nominal amplitude (high/low)	0.5 mm/0.2 mm
Static linear load (front/rear)	28.3/28.3 kg/cm
Vibration frequency (high/low amplitude)	48 Hz/67 Hz
Water tank volume	750 l



#### Compaction (CE)

Centrifugal force (high/low amplitude)	72 kN/51 kN
Vibration frequency (high/low amplitude)	48 Hz/62 Hz



#### Engine

Manufacturer/Model	Cummins QSB 3.3 IIIA/T3
Type	Water cooled turbo Diesel
Rated power, SAE J1995	74 kW (99 hp) @ 2200 rpm



#### Engine

Manufacturer/Model	Deutz TCD 3.6 HT StageV
Type	Water cooled turbo Diesel
Rated power, SAE J1995	55 kW (74 hp) @ 2200 rpm



#### Hydraulic system

Driving	Axial piston pump with variable displacement Axial piston motors (4) with variable displacement
Vibration	Axial piston pumps (2) with variable displacement Axial piston motors (2) with constant displacement
Steering	Gear pump with constant displacem.
Service brake	Hydrostatic in forward and reverse lever.
Parking/ Emergency brake	Failsafe multidisc brake in both drums.

Find us locally at [www.dynapac.com](http://www.dynapac.com)

We reserve the right to change specifications without notice. Photos and illustrations do not always show standard versions of machines. The above information is a general description only, all informations are supplied without liability.

# Dynapac CC2300

## Double drum vibratory rollers



### Technical data

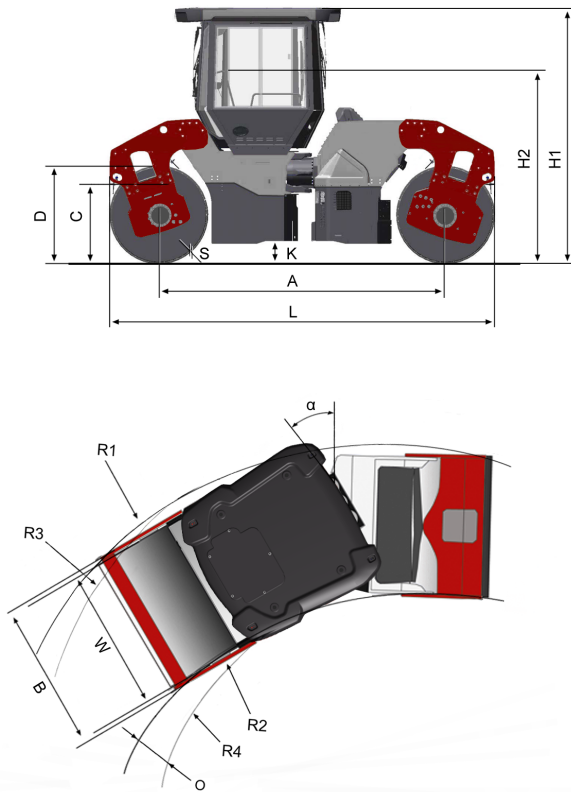

Dimensions	
A. Wheelbase	3340 mm
B. Width	1620 mm
C. Curb clearance	715 mm
D. Drum diameter	1150 mm
H1. Height, with ROPS/cab	2990 mm
K. Ground clearance	270 mm
L. Length	4490 mm
O. Off-set	335 mm
R1. Turning radius, outside	6570 mm
R2. Turning radius, inside	5070 mm
R3. Turning radius with off-set, outside	4890 mm
R4. Turning radius with off-set, inside	3390 mm
S. Drum shell thickness	17 mm
W. Drum width	1500 mm
α. Steering angle	±32°



### Optional equipment

#### Air Conditioning /Automatic Climate Control (ACC) (Optional)

- The system contains fluorinated greenhouse gases.
- Coolant designation: HFC-134a
- Coolant weight when full: 1,35 kg
- CO<sub>2</sub>-equivalent: 1,930 ton
- GWP: 1430

Find us locally at [www.dynapac.com](http://www.dynapac.com)

We reserve the right to change specifications without notice. Photos and illustrations do not always show standard versions of machines. The above information is a general description only, all informations are supplied without liability.