

# Dynapac F800W

## Wheeled pavers



### Technical data



#### Masses

Mass (incl. standard screed)	17.30 t
Weight	14.50 t



#### Dimensions

Working width, max.	5.79 m
Working width, hydraulic extendable	4.57 m
Working width, minimum (with reducing shoe)	1.83 m
Transport dimensions (LxWxH)	6.2 x 2.6 x 3.0 m
Deck height	1.69 m
Front ramp angle	14°



#### Capacity

Theoretical placement capacity	907 t/h
Practical placement capacity	544 t/h
Paving thickness (max/min)	-150 to 300 mm



#### Material hopper

Capacity	5.6 m <sup>3</sup> (12.0 t)
Dumping height (center/outside)	580 mm /715 mm
Hopper width, internal	3300 mm



#### Traction

Paving speed	0-35 m/min
Maximum paving speed	78 m/min
Transport speed	17.5 km/h
Turning radius	1.5 m



#### Engine

Manufacturer/Model	Cummins QSB 6.7-173
Rated power	129 kW (173 hp ) @ 2300 rpm
Rated power (Eco mode)	134 kW (180 hp ) @ 1,800 rpm
Emissions according to	STAGE IV /TIER 4f
Electrical system	24V /70A
Generator (tractor mounted)	34 kW
Fuel tank capacity	300 l



#### Undercarriage

Tyre size	2 x 16.00-20 E-7
Front wheels	4 x 360 mm x 500 mm
Final drive	Hydrostatic final drives - 2 Speed Motor & 2 Speed planetary



#### Conveyor

Conveyor type	Dual bar feeder
Conveyor width	2 x 506 mm
Conveyor control	Two independent conveyor half's with infinitely variable speed. Both half's can be controlled separately. Conveyor control independent of Augers by Ultrasonic sensors.



#### Auger

Auger diameter	430 mm
Auger control	Center drive. Two reversible augers with proportional speed control. Left and right augers to be controlled separately by Ultrasonic sensors.
Auger height adjustment	Infinitely variable by 254 mm

Find us locally at [www.dynapac.com](http://www.dynapac.com)

We reserve the right to change specifications without notice. Photos and illustrations do not always show standard versions of machines. The above information is a general description only, all informations are supplied without liability.



Operation

Operator console	Dual Swing out
Dashboard	Ergonomic with Multifunction display /console Simplified smart switches, Cup holder

Find us locally at [www.dynapac.com](http://www.dynapac.com)

We reserve the right to change specifications without notice. Photos and illustrations do not always show standard versions of machines.  
The above information is a general description only, all informations are supplied without liability.

# Dynapac F800W

## Wheeled pavers



### Technical data

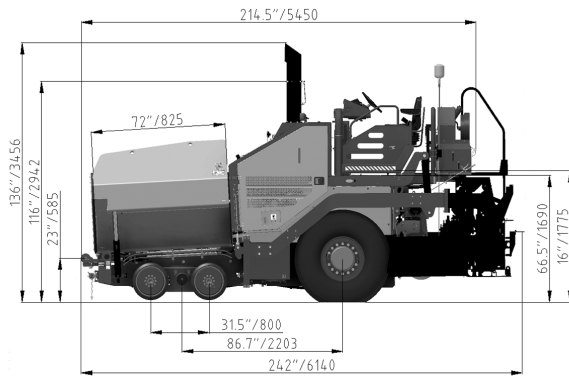

Optional equipment	
Type	Equipment
Leveling control	Topcon
Extensions	Auger Extension kit
	Hydraulic Tunnel Extension kit
	Wide Width Package
Lubrication	Centralized Lubrication System
Push Roller	Safe Impact System
Hopper Aprons	Powered Hopper Aprons
Traction System	2 Front wheel Drive assist
	4 Front wheel Drive assist

Find us locally at [www.dynapac.com](http://www.dynapac.com)

We reserve the right to change specifications without notice. Photos and illustrations do not always show standard versions of machines. The above information is a general description only, all informations are supplied without liability.