

Engine V2203-M

Engine power 35,6 kW - 48,4 HP

Operating Weight 2.380 kg

ETL 140.5

Concrete solutions. Always



 **EUROCOMACH®**

TECHNICALS SPECIFICATIONS

Operating weight	kg	2.380
ENGINE		
Type	KUBOTA V2203 EU STAGE IIIA	
Max Power (2.600 rpm)	kW - HP	35,6 - 48,4
Max torque (1.700 rpm)	Nm	95
Displacement	cc	2.200
Number of cylinders	n°	4 in line
Cooling	water	
Consumption	lt/h	7,9
Alternator	V (A)	12 (45)
Battery	V (Ah)	12 (80/550)
HYDRAULIC SYSTEM		
Pump type	n.1 with gears for services	
Pump capacity	lt/min	43
Max. circuit calibration pressure	bar	180
Auxiliary system:	Max capacity	lt
	Max pressure	bar
High Flow System (optional):	Max capacity	lt
	Max pressure	bar
TRANSMISSION		
Type	Hydrostatic with double pump and TRASMITAL-KAYABA gearboxes.	
Travelling speed	km/h	1 ^a : 0 ÷ 6 / 2 ^a : 0 ÷ 10,5
Traction force	daN	1 ^a : 2.400 / 2 ^a : 1.600
Tracks width	mm	250
BRAKES		
Service brakes	Hydrostatic	
Parking brakes	Negative with multiple disks into oil bath, integrated on the rear gearboxes at electrohydraulic control	
Emergency brakes	Electrohydraulic control, acting on parking brakes (integrated on the rear gearboxes)	
PERFORMANCES		
Tipping load (ISO 14397)	kg	1.485
Operating load (no more than 50% of tipping load)	kg	743
Operating load (ISO 14397, no more than 35% of tipping load)	kg	520
Teeth breakout force	daN	1.430
Standard bucket capacity	m³	0,30
Standard bucket width	mm	1.300
Ground bearing pressure	kg/cm²	0,37
Max slope	60% - 30°	
FILLINGS		
Fuel tank	lt	52
Hydraulic oil tank	lt	42
Hydraulic circuit capacity	lt	57
Cooling system capacity	lt	10
Engine oil	lt	7,2
CONTROLS		
Type	Ergonomic joystick with security block on board	
Translation	Driven by left joystick	
Services	Driven by right joystick for lifting and bucket	
Lifting mechanism	Bucket self-levelling system standard (only when lifting the arm)	

ETL 140.5

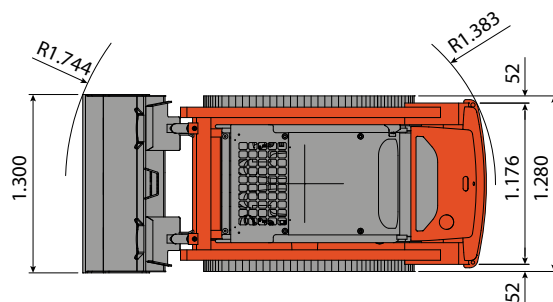
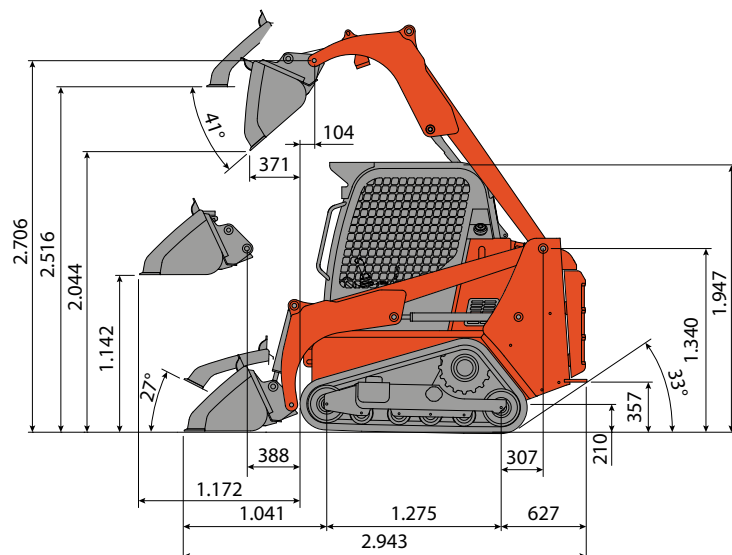

- Homologation for road traffic (only Italy).
- ROPS ISO 3471 and FOPS 3449 homologated cabin with hardened upper and rear standard glasses (side glasses on demand).
- Front and back working lights for night road circulation.



EUROCOMACH®

MADE IN ITALY

Sampierana S.p.a.

47021 S.Piero in Bagno (FO)

via Leonardo da Vinci, 40

Tel +39 0543.904211

Fax +39 0543.918520

www.eurocomach.com