

Engine V1505

Engine power 26,1 kW - 35,5 HP

Operating Weight 1.830 kg

ESK 130.5

Concrete solutions. Always



 **EUROCOMACH®**

TECHNICALS SPECIFICATIONS

Operating weight	kg	1.830
ENGINE		
Type	KUBOTA V1505 EU Stage IIIA	
Max Power (2.500 rpm)	kW- HP	26,1 - 35,5
Max torque (2.200 rpm)	Nm	95
Displacement	cc	1.498
Number of cylinders	n°	4 in line
Cooling	water	
Consumption	lt/h	5,8
Alternator	V (A)	12 (30)
Battery	V (Ah)	12 (74/680)
HYDRAULIC SYSTEM		
Pump type	n.1 with gears for services	
Pump capacity	lt/min	43
Max. circuit calibration pressure	bar	180
Auxiliary system:	Max capacity	lt 43
	Max pressure	bar 180
High Flow System (optional):	Max capacity	lt 65
	Max pressure	bar 180
TRANSMISSION		
Type	Hydrostatic with double pump and 4 gearboxes on the wheels type TRASMITAL-DANFOSS	
Travelling speed	km/h	1 ^a : 0 ÷ 12
Traction force	daN	1.400
Dimensions tires	27/8,50x15	
BRAKES		
Service brakes	Hydrostatic	
Parking brakes	Negative with multiple disks into oil bath, integrated on the rear gearboxes at electrohydraulic control	
Emergency brakes	Electrohydraulic control, acting on parking brakes (integrated on the rear gearboxes)	
PERFORMANCES		
Tipping load (ISO 14397)	kg	970
Operating load (ISO 14397, no more than 50% of tipping load)	kg	485
Teeth breakout force	daN	1.300
Standard bucket capacity	m ³	0,28
Standard bucket width	mm	1.250
Max slope	60% - 30°	
FILLINGS		
Fuel tank	lt	48
Hydraulic oil tank	lt	44
Hydraulic circuit capacity	lt	59
Cooling system capacity	lt	12
Engine oil	lt	5
CONTROLS		
Type	Ergonomic joystick with security block on board	
Translation	Driven by left joystick	
Services	Driven by right joystick for lifting and bucket	
Lifting mechanism	Bucket self-levelling system standard (only when lifting the arm)	

ESK 130.5

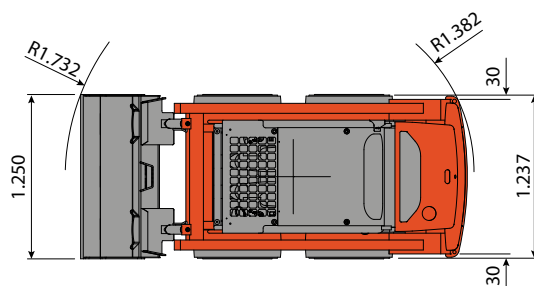
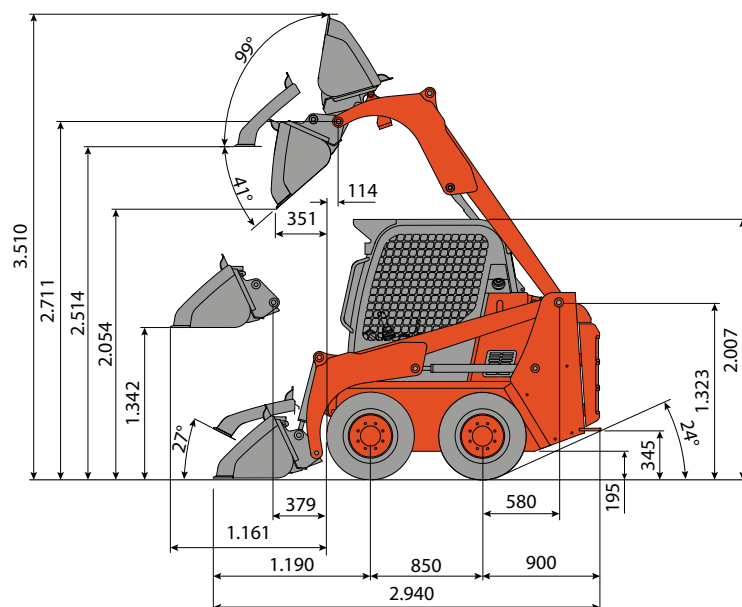

Hydrostatic transmission

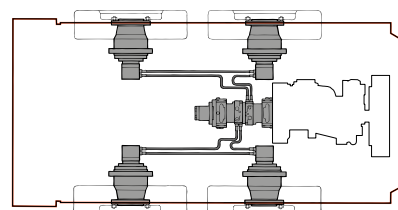

The gearboxes, compared with the traditional transmission by chain, which is subject to frequent repair and maintenance operations, have many advantages such as an elevated transfer speed (11,5 km/h), homogenous distribution of the power directly on the wheels in favour of the force, a higher sensibility of movements, the favourable possibility to work if need be, mounting old and new tyres on the same side without compromising the reliability of the machine.

- Homologation for road traffic (only Italy).
- ROPS ISO 3471 and FOPS 3449 homologated cabin with hardened upper and rear standard glasses (side glasses on demand).
- Front and back working lights for night road circulation.



EUROCOMACH®

MADE IN ITALY

Sampierana S.p.a.

47021 S.Piero in Bagno (FO)
via Leonardo da Vinci, 40

Tel +39 0543.904211

Fax +39 0543.918520

www.eurocomach.com