

Engine 4TNV98CT
Engine power 53,7 kW - 73,0 HP
Operating Weight 9.900 kg

ES 95 TR₄

Concrete solutions. Always



TIER₄

 **EUROCOMACH®**

TECHNICALS SPECIFICATIONS

Operating weight (with rubber track)	kg	9.900
Operating weight (with steel track)	kg	10.220
Travelling speed (AUTO TWO SPEED)	km/h	1 ^a : 0 ÷ 2,6 / 2 ^a : 0 ÷ 4,5
Slew speed	rpm	10

ENGINE

Type	YANMAR 4TNV98CT EU Stage IIIB - EPA Tier 4	
Power (2.100 rpm)	kW - HP	53,7 - 73,0
Displacement	cc	3.319
Number of cylinders	n°	4
Cooling	water	
Consumption	lt/h	8,7
Alternator	V (A)	12 (55)
Battery	V (Ah)	12 (100)

HYDRAULIC SYSTEM

Circuit Type	Load Sensing system with flow sharing control valve with 11 elements	
Pump type	LS Hydraulic pump with electronic control	
Pump displacement	cc	84 + 9
Pump capacity	lt/min	185 + 19
Max. circuit calibration pressure	bar	290 - 200 - 35
Auxiliary Flow (max pressure): AUX 1 Main High Flow AUX 2 High Flow AUX 3 Low Flow	lt/min (bar)	100 / 100 (200) 90 / 80 (290) 50 / 50 (290)

PERFORMANCES

Max digging depth standard arm (optional arm)	mm	4.570 (4.920)
Max dumping height with cab standard arm (optional arm)	mm	6.070 (6.370)
Bucket breaking force (standard arm) ISO 6015	daN	5.500
Arm breaking force (standard arm) ISO 6015	daN	4.350
Traction force	daN	7.960
Ground bearing pressure with rubber tracks	kg/cm ²	0,46
Max slope	60% - 30°	

DIMENSIONS

Max. width	mm	2.320
Total height	mm	2.560
Rear rotation radius	mm	1.155
Digging arm length std (optional)	mm	1.760 (2.110)
Tracks width	mm	450
Rollers number (for each side)	n°	5/1 (rubber track) 6/1 (steel track)

FILLINGS

Fuel tank	lt	105
Hydraulic oil tank	lt	90
Hydraulic circuit capacity	lt	120
Cooling system capacity	lt	25
Engine oil	lt	10

CONTROLS

Boom, dipper stick, bucket and turret swing	2 pilot joysticks
Tracks movement (included counter rotation)	2 pilot levers
Dozer blade	pilot lever
Auxiliary circuit (simple or double effect)	electroproportional switch on right joystick
Boom swing	electroproportional switch on left joystick

ES 95 TR₄

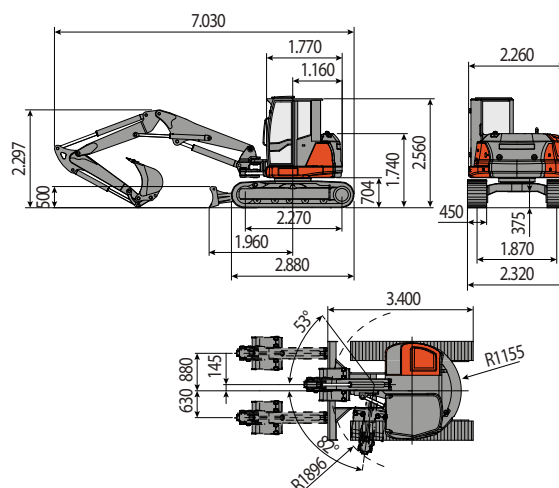
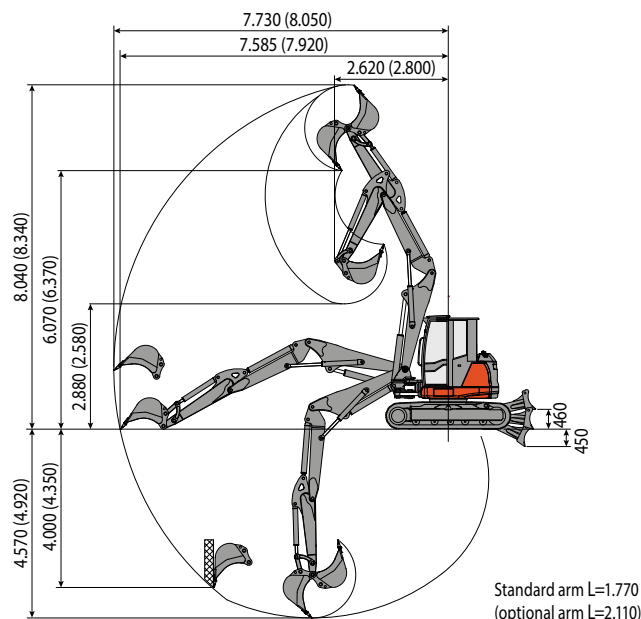

LIFTING CAPACITY

Opening arm from the rotation's center (m)
Lifting capacity (kg) at 1.5 m height

	3	4	5	6	MAX
Frontal and lowered dozer blade	4045	2830	2110	1750	1580
Frontal and lifted dozer blade	2760	1930	1235	1000	920
Lateral	3150	1760	1300	990	840

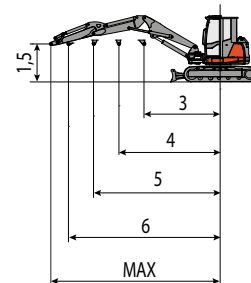

The lifting capacity is based on the ISO 10567 and it does not exceed more than the 75% of static tipping load or more than the 87% of the hydraulic lifting capacity of the machine.



EUROCOMACH[®]

MADE IN ITALY



Sampierana S.p.a.

47021 S.Piero in Bagno (FO)

via Leonardo da Vinci, 40

Tel +39 0543.904211

Fax +39 0543.918520

www.eurocomach.com