

Engine V2607-DI

Engine power 33,8 kW - 46,0 HP

Operating weight 5.950 - 6.050 kg

ES 60 TR

Concrete solutions. Always



 **EUROCOMACH®**

TECHNICALS SPECIFICATIONS

Operating weight with canopy (with rubber tracks)	kg	5.950
Operating weight with cabin (with rubber tracks)	kg	6.050
Travelling speed (AUTO TWO SPEED)	km/h	1 ^a : 0 ÷ 2,6 / 2 ^a : 0 ÷ 5,2
Slew speed	rpm	11

ENGINE

Type	KUBOTA V2607-DI	
Max Power (2.200 rpm)	kW - HP	33,8 - 46,0
Displacement	cc	2.615
Number of cylinders	n°	4
Cooling	water	
Consumption	lt/h	6,1
Alternator	V (A)	12 (60)
Battery	V (Ah)	12 (100)

HYDRAULIC SYSTEM

Circuit Type	load sensing closed center system with flow sharing control valve	
Pump type	1 ls variable pump + 1 gear pump	
Pump displacement	cc	65 + 8
Pump capacity	lt/min	140 + 17
Max. circuit calibration pressure	bar	260
Low flow (high flow) auxiliary circuit:	Max capacity Max pressure	lt/min bar
		35 ÷ 50 (70) 260 (200)

PERFORMANCES

Max digging depth standard arm (optional arm)	mm	3.950 (4.200)
Max dumping height with cab standard arm (optional arm)	mm	5.400 (5.640)
Bucket breaking force (standard arm) ISO 6015	daN	4.500
Arm breaking force (standard arm) ISO 6015	daN	2.800
Traction force	daN	5.200
Ground bearing pressure with rubber tracks and canopy (with cabin)	kg/cm ²	0,36 (0,37)
Max slope	60% - 30°	

DIMENSIONS

Maximum width	mm	1.980
Total height	mm	2.560
Rear rotation radius	mm	1.075
Digging arm length std (optional)	mm	1.650 (1.900)
Tracks width	mm	400
Rollers number (for each side)	n°	5/1

FILLINGS

Fuel tank	lt	70
Hydraulic oil tank	lt	65
Hydraulic circuit capacity	lt	85
Cooling system capacity	lt	12
Engine oil	lt	9

CONTROLS

Boom, dipper stick, bucket and turret swing	2 pilot joysticks
Tracks movement (included counter rotation)	2 pilot levers
Dozer blade	pilot lever
Auxiliary circuit (simple or double effect)	electroproportional switch on right joystick
Boom swing	electroproportional switch on left joystick

ES 60 TR

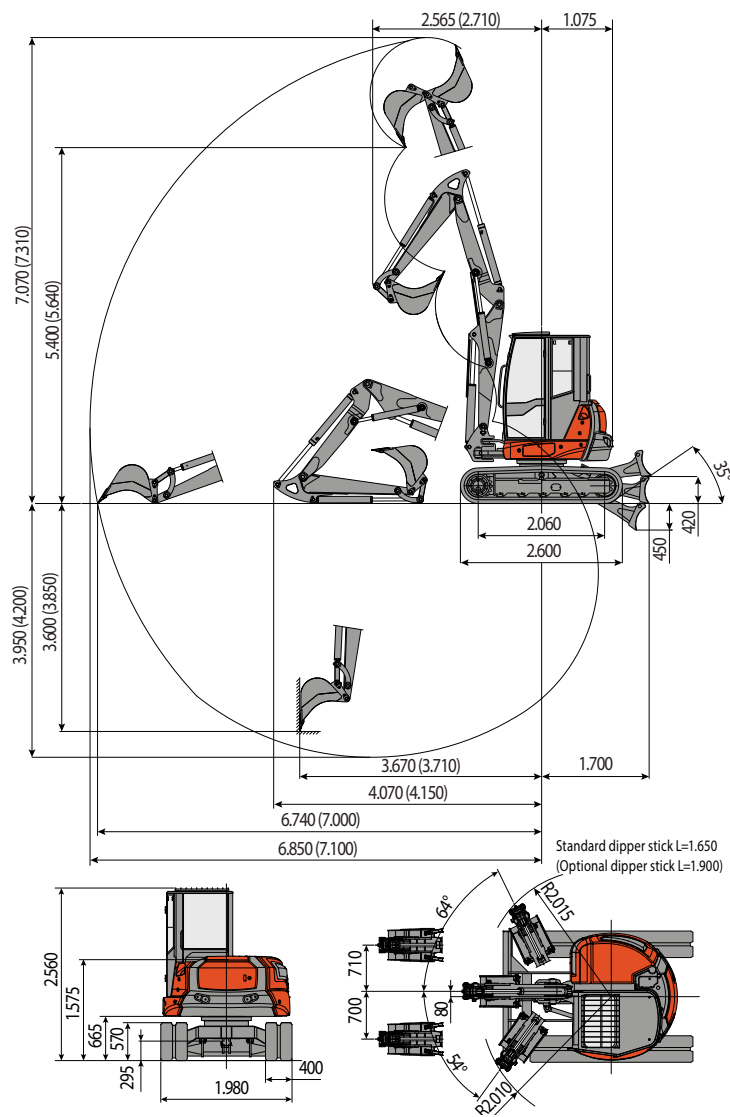

LIFTING CAPACITY

Opening arm from the rotation's center (m)
Lifting capacity (kg) at 1.0 m height

	3	3,5	4	4,5	5	5,5	MAX
Frontal and lowered dozer blade	2462	1966	1670	1418	1233	1052	914
Frontal and lifted dozer blade	1819	1410	1121	900	745	641	540
Lateral	1365	1110	890	739	630	544	473

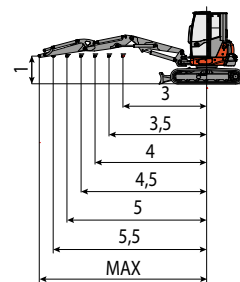

The lifting capacity is based on the ISO 10567 and it does not exceed more than the 75% of static tipping load or more than the 87% of the hydraulic lifting capacity of the machine.



EUROCOMACH®

MADE IN ITALY



Sampierana S.p.a.

47021 S.Piero in Bagno (FO)

via Leonardo da Vinci, 40

Tel +39 0543.904211

Fax +39 0543.918520

www.eurocomach.com