

Engine D1803-M

Engine power 28,3 kW - 38,0 HP

Operating weight 3.800 - 3.950 kg

ES40.2ZT

Concrete solutions. Always



 **EUROCOMACH®**

TECHNICALS SPECIFICATIONS

Operating weight with canopy (with rubber tracks)	kg	3.800
Operating weight with cabin (with rubber tracks)	kg	3.950
Travelling speed (AUTO TWO SPEED)	km/h	1 ^a : 0 ÷ 2,5 / 2 ^a : 0 ÷ 4,6
Slew speed	rpm	10

ENGINE

Type	KUBOTA D1803-M	
Max Power (2.300 rpm)	kW - HP	28,3 - 38,0
Displacement	cc	1.826
Number of cylinders	n°	3
Cooling	water	
Consumption	lt/h	5,2
Alternator	V (A)	12 (40)
Battery	V (Ah)	12 (80)

HYDRAULIC SYSTEM

Circuit Type	load sensing centre fermée avec distributeur flow sharing	
Pump type	1 pompe ls debit variable + 1 pompe a engranages	
Pump displacement	cc	48 + 5
Pump capacity	lt/min	105 + 10
Max. circuit calibration pressure	bar	250
Auxiliary system: Max capacity	lt/min	50
Max pressure	bar	200

PERFORMANCES

Max digging depth standard arm (optional arm)	mm	3.200 (3.450)
Max dumping height with cab standard arm (optional arm)	mm	3.530 (3.680)
Bucket breaking force (standard arm) ISO 6015	daN	3.200
Arm breaking force (standard arm) ISO 6015	daN	1.950
Traction force	daN	3.400
Ground bearing pressure with rubber tracks and canopy (with cabin)	kg/cm ²	0,32 (0,33)
Max slope	60% - 30°	

DIMENSIONS

Maximum width	mm	1.700
Total height	mm	2.535
Rear rotation radius	mm	845
Digging arm length std (optional)	mm	1.400 (1.650)
Tracks width	mm	350
Rollers number (for each side)	n°	4/1

FILLINGS

Fuel tank	lt	46
Hydraulic oil tank	lt	30
Hydraulic circuit capacity	lt	54
Cooling system capacity	lt	8
Engine oil	lt	7

CONTROLS

Boom, dipper stick, bucket and turret swing	2 pilot joysticks
Tracks movement (Included counter rotation)	2 pilot levers
Dozer blade	pilot lever
Auxiliary circuit (simple or double effect)	electroproportional switch on right joystick
Boom swing	electroproportional switch on left joystick

ES40.2ZT

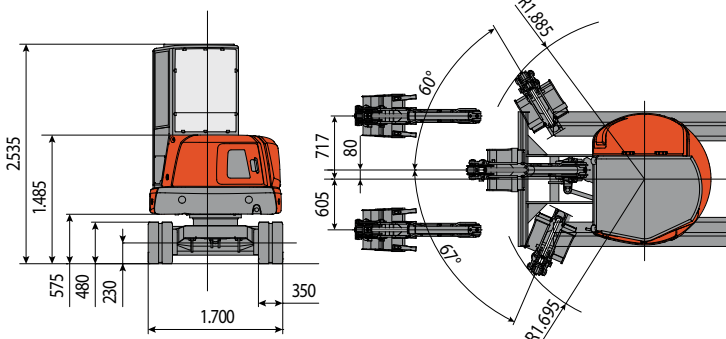
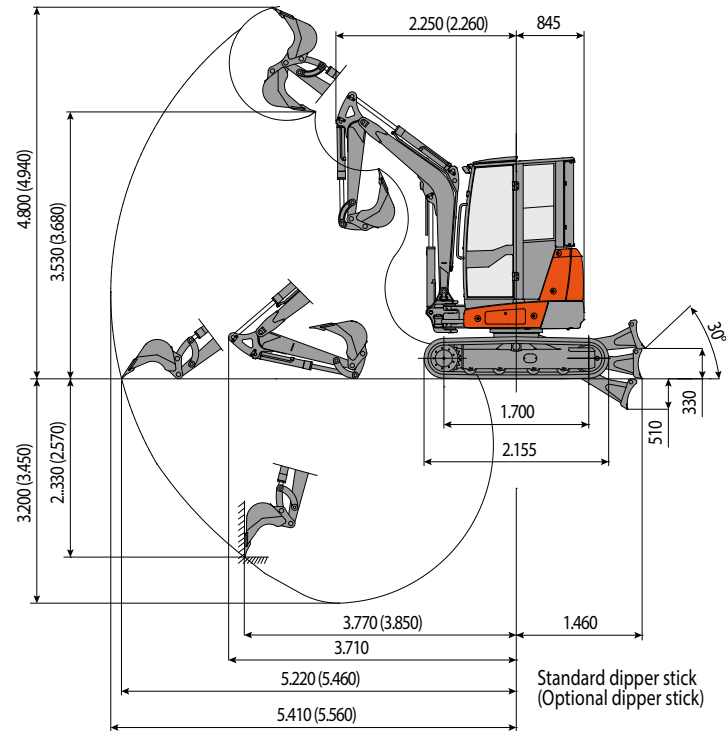

LIFTING CAPACITY

Opening arm from the rotation's center (m)
Lifting capacity (kg) at 1.0 m height

	2,5	3	3,5	4	4,5	MAX
Frontal and lowered dozer blade	1231	984	803	716	674	648
Frontal and lifted dozer blade	1096	863	665	536	450	437
Lateral	999	770	613	500	413	390

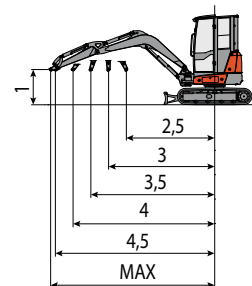

The lifting capacity is based on the ISO 10567 and it does not exceed more than the 75% of static tipping load or more than the 87% of the hydraulic lifting capacity of the machine.



EUROCOMACH®

MADE IN ITALY



Sampierana S.p.a.

47021 S.Piero in Bagno (FO)

via Leonardo da Vinci, 40

Tel +39 0543.904211

Fax +39 0543.918520

www.eurocomach.com