

Engine 3TNV70

Engine power 11,2 kW - 15,3 HP

Operating Weight 1.540 - 1.650 kg

ES 15 SR

Concrete solutions. Always



 **EUROCOMACH®**

TECHNICALS SPECIFICATIONS

Operating weight with canopy (with rubber tracks)	kg	1.540
Operating weight with cabin (rubber tracks)	kg	1.650
Travelling speed	km/h	1°: 0 ÷ 2,2 / 2°: 0 ÷ 4,2
Slew speed	rpm	12

ENGINE

Type	YANMAR 3TNV70	
Power (2.100 rpm)	kW - HP	11,2 - 15,2
Displacement	cc	854
Number of cylinders	n°	3
Cooling	water	
Consumption	lt/h	2,4
Alternator	V (A)	12 (35)
Battery	V (Ah)	12 (65)

HYDRAULIC SYSTEM

Pump type	variable flow	
Pump displacement	cc	8+8+6,5
Pump capacity	lt/min	17,6+17,6+14,3
Max. circuit calibration pressure	bar	210
Auxiliary system: Max capacity	lt/min	36
Max pressure	bar	210

PERFORMANCES

Max digging depth standard arm (optional arm)	mm	2.100 (2.250)
Max dumping height with canopy standard arm (optional arm)	mm	2.500 (2.620)
Max dumping height with cab standard arm (optional arm)	mm	2.350 (2.430)
Bucket breaking force (standard arm) ISO 6015	daN	1.550
Arm breaking force (standard arm) ISO 6015	daN	1.150
Traction force	daN	1.500
Ground bearing pressure with rubber tracks and canopy (with cabin)	kg/cm ²	0,28 (0,30)
Max slope	60° - 30°	

DIMENSIONS

Maximum width	mm	990
Total height	mm	2.357
Rear rotation radius	mm	650
Digging arm length std (optional)	mm	950 (1.100)
Tracks width	mm	230
Rollers number (for each side)	n°	3

FILLINGS

Fuel tank	lt	18
Hydraulic oil tank	lt	20
Hydraulic circuit capacity	lt	30
Cooling system capacity	lt	4
Engine oil	lt	2,8

CONTROLS

Boom, dipper stick, bucket and turret swing	2 pilot joysticks
Track movements (included counter rotation)	2 levers
Dozer blade	mechanical lever
Auxiliary circuit (simple or double effect)	left pedal
Boom swing	right pedal

ES 15 SR

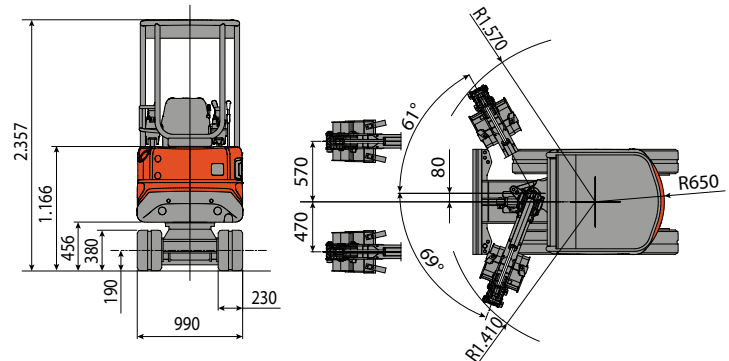
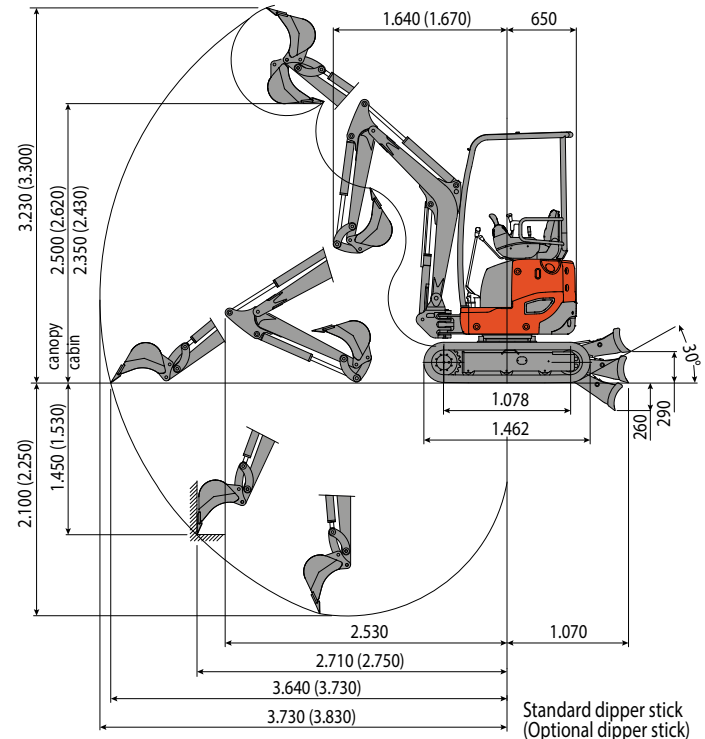

LIFTING CAPACITY					
Opening arm from the rotation's center (m)					
Lifting capacity (kg) at 1.0 m height					
	1,5	2	2,5	3	MAX
Frontal and lowered dozer blade	750	460	380	325	280
Frontal and lifted dozer blade	540	380	265	165	160
Lateral	400	270	160	120	100

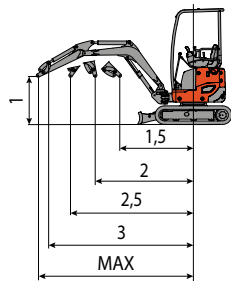

The lifting capacity is based on the ISO 10567 and it does not exceed more than the 75% of static tipping load or more than the 87% of the hydraulic lifting capacity of the machine.



EUROCOMACH
MADE IN ITALY



Sampierana S.p.a.

47021 S.Piero in Bagno (FO)
via Leonardo da Vinci, 40
Tel +39 0543.904211
Fax +39 0543.918520
www.eurocomach.com