



TM

VENIERI
SPA

2.63C

2.63C *Plus*

3.63G

WHEEL LOADER





LITTLE BIG ONES.

REDUCED SIZE, UNSTOPPABLE POWER



Increase your expectations: Venieri's small ones are here!

Thanks to the widely tested project evolution matching the new market requirements, the new machines represent a significant improvement. We are located in the "Motor Valley" which, in a small territory, has always been giving birth to fabulous cars and top performing motorbikes! The genetic heritage is very rich: the **Japanese technology** of the **Yanmar engines**, **new Bosch Rexroth transmissions** and a **ratio traction/weight** never before achieved. The **ORA** (oscillating rear axle) is one of the main organs in this series: **there isn't any oscillating mechanical coupling** between the front and rear, ensuring smart working and driving safety on these small ones which can be normally found on big machines only.

2.63C

- › "Z" Linkage
- › Max power **50 HP**
- › Bucket capacity **0,70 m³**
- › Max permis. weight **4.800 kg**
- › Std operat. weight **4.150 kg**

2.63C *Plus*

- › "Z" Linkage
- › Max power **50 HP**
- › Bucket capacity **0,75 m³**
- › Max permis. weight **4.800 kg**
- › Std operat. weight **4.350 kg**

3.63G

- › "Z" Linkage
- › Max power **60 HP**
- › Bucket capacity **0,80 m³**
- › Max permis. weight **5.750 kg**
- › Std operat. weight **4.900 kg**

ENGINE: JAPANESE TECHNOLOGY

The **4 TNV 88** and **84T Yanmar** engines are designed to match all types of requirements: **low environmental impact**, **low noise** and **limited vibration** transform these engines perfect partners. The continuous efforts to find sustainable solutions to essential needs of human life makes **Yanmar engines** the **best** in terms of **power economy** and **emissions**; **simplicity** and **reliability** are the two main features that brought Venieri to choose Yanmar engines.



TRANSMISSION: GLOBAL QUALITY

There are many ways to transmit power but only one is able to satisfy even the most demanding customers: **Venieri** and **Bosch-Rexroth** laboratories have studied and developed **one of the best possible combinations of high pressure transmission** (so **high efficiency transmission with 500 bar***). In that way the **efficiency** of Venieri's wheel loaders led to a **11% improvement**: try and you'll believe it!

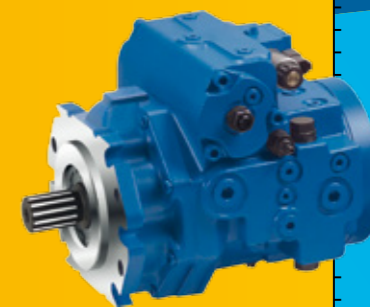

Extended performance range

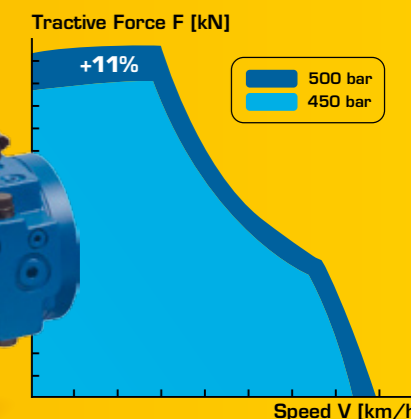

AXLE: TOP LEVEL EQUIPMENT

The **double fixing** on each side grants **extreme reliability and stiffness to the chassis even after 8000/10000 working hours** and represents a further confirmation of our design philosophy: **small size machines equally designed as the big ones!** The **18° rear oscillation** grants perfect **stability and security** during working and transfer operations. Electrically driven 100% blocking slip differential.



GREASING: CENTRALIZED COMFORT

Maintenance is fundamental on all machines: Venieri decided to build machines **easy and accessible to anyone**: machines whose maintenance operations can be carried out in an **easy and safe way**, thanks to its particular design. For example, the **3 points of centralized greasing** allow the **rear axle** and the **swinging** to be instantly double checked.



WHEEL LOADER › “Z” LINKAGE



DIESEL ENGINE

4-cylinder engine: port fuel injection, water cooling, paper dry filtering. Emissions as per EC 97/68 stage IIIA rules.

Type	Yanmar 4TNV88
Max Power	36kW - 50 HP
Rated rpm	3.000
Power ISO/TR 14396	35 kW - 48 HP
Power EEC/80/1269	35 kW - 48 HP
Bore	mm 88
Stroke	mm 90
Displacement	cm ³ 2.190

ELECTRIC SYSTEM

Battery	12 Volt
Capacity EN 60095-1	80 Ah - 770 A
Alternator rating	65 A
Reverse warning	Standard
Wiring according to rules	IP 67 e DIN 40050

TRANSMISSION

Hydrostatic transmission with automatic power regulation and closed circuit with variable-displacement pump and engine. Two forward/reverse speeds with single-lever control.

	forward	reverse
1 st Gear km/h	0÷7	0÷7
2 nd Gear km/h	0÷20	0÷20

AXLES

All wheel drive. Two heavy duty axles with planetary final drives on each wheel.

Fixed rigid drive axle on front chassis section. Oscillating drive axle on rear chassis section up to a 20° total angle.

Transfer gearbox allowing the rear and the front movement by means of a transmission shaft.

Self-locking limited slip differential on front axle (optional on rear axle).

BRAKES

Service: drum-brake hydraulically operating on front axle working on all wheels. Parking brake: mechanical drum-brake operating on service brake, manually activated.

TYRES

Standard 12.0/75-18 12pr
Optional 10.5-18 10pr • 12.5-18 10pr • 15.5/55 R18

STEERING

Servo assisted steering by means of a hydraulic LOAD SENSING system.

Total steering angle	80°
Inner steering angle	mm 2.193
External tyres turning radius	mm 3.790
External bucket turning radius	mm 4.210

HYDRAULIC SYSTEM

Hydraulic gear pump with LOAD SENSING priority valve for steering circuit. 2-section modular control valve with main relief valve. Double-acting hydraulic cylinders. Hydraulic oil cooling radiator. Full-flow oil filter on the return circuit. Single control cloche-lever with 4-position bucket lifting system and 3-position auxiliary control system.

Max flow	lt/'	60
Loader relief valve pressure	bar	200
Steering relief valve pressure	bar	190
Lifting cylinder	mm	70x937
Bucket cylinder	mm	80x395

SERVICES CAPACITIES

Engine	lt	8
Front axle	lt	5,8
Rear axle + gear box	lt	6,5
Hydraulic circuit	lt	57
Brake system	lt	1,1
Fuel	lt	70
Water cooling	lt	10

TECHNICAL FEATURES

Standard bucket capacity	m ³	0,70
Bucket width	mm	1.700
Straight static tipping load	kg	3.000
Full turned 40° tipping load	kg	2.700
Lifting capacity at max. height	kg	2.700
Dump clearance	mm	3.100
Dump height at 43°	mm	2.450
Reach at 43°	mm	650
Breakout force	kg	4.700

DIMENSIONS AND WEIGHT

Max length in transfer position	mm	4.800
Max width in transfer position	mm	1.700
Max height	mm	2.460
Track width	mm	1.320
Overall tyre width	mm	1.640
Wheel base	mm	1.950
Ground clearance	mm	370
Standard operating weight	kg	4.150
Max permissible weight	kg	4.800

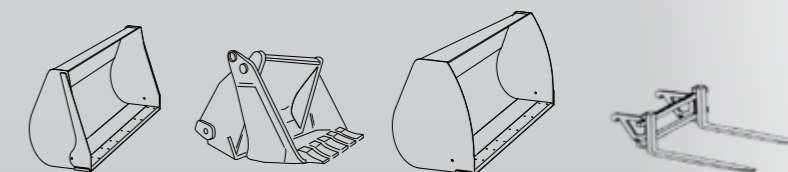
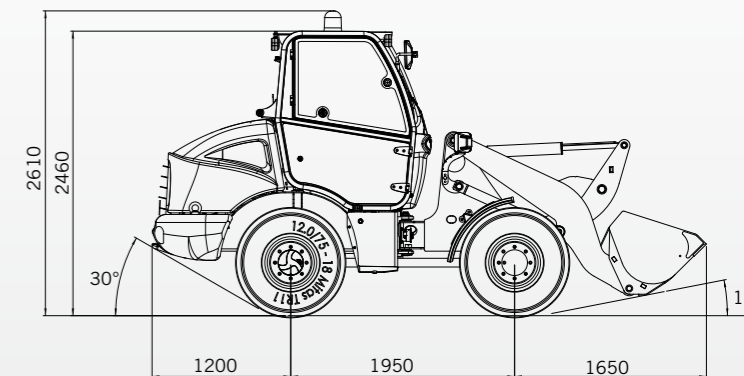
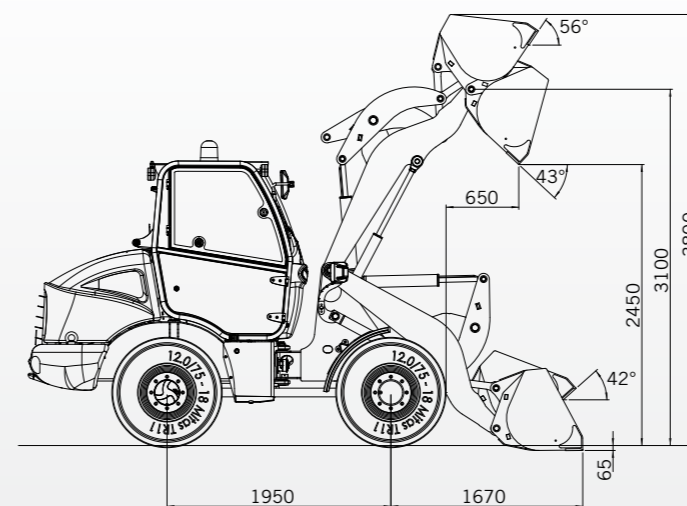

PERFORMANCE DATA

		UNIVERSAL BUCKET	MULTI PURPOSE BUCKET	OVERSIZE	FORKS
Full load bucket capacity (SAE)	m ³	0,75	0,6	1,2	/
Bucket width	mm	1.700	1.700	1.900	/
Bucket weight	kg	250	250	350	/
Max operative height	mm	3.800	3.750	3.850	/
Forks length (Standard)	mm				1.000
Forks length (Optional)	mm				1.200
Height to hinge pin	mm	3.100	3.100	3.100	/
Dump angle	°	43°	43°	43°	/
Dump height	mm	2.450	2.500	2.400	/
Reach fully raised	mm	650	600	700	/
Max dump distance	mm	1.450	1.400	1.500	/
Bucket static tipping load, straight	kg	3.000	2.900	2.700	/
Bucket static tipping load, full turn (40°)	kg	2.700	2.600	2.400	/
Forks static tipping load, full turn (40°)	kg				2.200
Forks Payload EN 474-3 (80%)	kg				1.760
Forks Payload EN 474-3 (60%)	kg				1.400
Breakout force	kg	4.700	5.100	4.400	/
Total length	mm	4.800	4.750	4.800	/
External bucket turning radius	mm	4.200	4.000	4.300	/
Standard operative weight	kg	4.150	4.200	4.200	/

WHEEL LOADER › “Z” LINKAGE

DIESEL ENGINE

Engine: 4 cylinders, direct injection, water cooled, paper dry filter. Emissions in accordance with EC 97/68 stage IIIA rules.

Type	Yanmar 4TNV88
Max Power	36kW - 50 HP
Rated rpm	3.000
Power ISO/TR 14396	35 kW - 48 HP
Power EEC/80/1269	35 kW - 48 HP
Bore	mm 88
Stroke	mm 90
Displacement	cm ³ 2.190

ELECTRIC SYSTEM

Battery	12 Volt
Capacity EN 60095-1	80 Ah - 770 A
Alternator rating	65 A
Reverse warning	Standard
Wiring according to rules	IP 67 e DIN 40050

TRANSMISSION

Hydrostatic transmission with automatic power regulation and closed circuit with variable-displacement pump and engine. Two forward/reverse speeds with single-lever control.

	forward	reverse
1 st Gear km/h	0÷7	0÷7
2 nd Gear km/h	0÷28	0÷28

AXLES

All wheel drive. Two heavy duty axles with planetary final drives on each wheel. Fixed rigid drive axle on front chassis section. Oscillating drive axle on rear chassis section up to a 20° total angle. Transfer gearbox allowing the rear and the front movement by means of a transmission shaft. Electrically driven 100% blocking slip differential, on front axle and open on rear axle.

BRAKES

Service: drum-brake hydraulically operating on front axle working on all wheels. Parking brake: mechanical drum-brake operating on service brake, manually activated.

TYRES

Standard	12.0/75-18 12pr
Optional	10.5-18 10pr • 12.5-18 10pr • 15.5/55 R18

STEERING

Servo assisted hydraulic steering with LOAD SENSING system.	
Total steering angle	80°
Inner tyres turning radius	mm 2.193
External tyres turning radius	mm 3.790
External bucket turning radius	mm 4.210

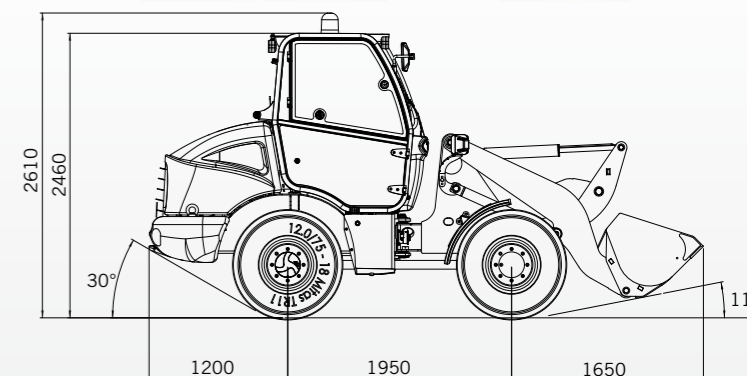
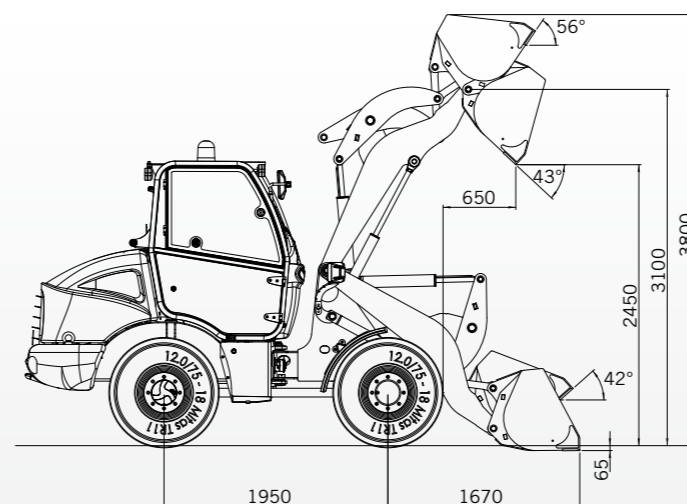

HYDRAULIC SYSTEM

Hydraulic gear pump with LOAD SENSING priority valve for steering circuit. 2-section modular control valve with main relief valve. Double-acting hydraulic cylinders. Hydraulic oil cooling radiator. Full-flow oil filter on the return circuit. Single control cloche-lever with 4-position bucket lifting system and 3-position auxiliary control system.

Max flow	lt/1'	60
Loader relief valve pressure	bar	230
Steering relief valve pressure	bar	190
Lift cylinder	mm	70x937
Bucket cylinder	mm	80x395

SERVICES CAPACITIES

Engine	lt	8
Front axle	lt	5,8
Rear axle + gear box	lt	6,5
Hydraulic circuit	lt	57
Brake system	lt	1,1
Fuel	lt	70
Water cooling	lt	10

TECHNICAL FEATURES

Standard bucket capacity	m ³	0,75
Standard bucket width	mm	1.700
Straight static tipping load	kg	3.300
Full turned 40° tipping load	kg	3.000
Lifting capacity at max. height	kg	3.100
Dump clearance	mm	3.100
Dump height at 43°	mm	2.450
Reach at 43°	mm	650
Breakout force	kg	5.300

DIMENSIONS AND WEIGHT

Max length in transfer position	mm	4.800
Max width in transfer position	mm	1.700
Max height	mm	2.460
Track width	mm	1.320
Overall tyre width	mm	1.640
Wheel base	mm	1.950
Ground clearance	mm	370
Standard operating weight	kg	4.350
Max permissible weight	kg	4.800

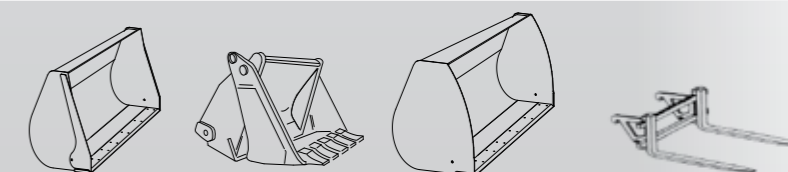

PERFORMANCE DATA

		UNIVERSAL BUCKET	MULTI PURPOSE BUCKET	OVERSIZE	FORKS
Full load bucket capacity (SAE)	m ³	0,75	0,6	1,2	/
Bucket width	mm	1.700	1.700	1.900	/
Bucket weight	kg	250	350	350	/
Max operative height	mm	3.800	3.750	3.850	/
Forks length (Standard)	mm				1.000
Forks length (Optional)	mm				1.200
Height to hinge pin	mm	3.100	3.100	3.100	/
Dump angle	°	43°	43°	43°	/
Dump height	mm	2.450	2.500	2.400	/
Reach fully raised	mm	650	600	700	/
Max dump distance	mm	1.450	1.400	1.500	/
Bucket static tipping load, straight	kg	3.300	3.200	2.900	/
Bucket static tipping load, full turn (40°)	kg	3.000	2.900	2.700	/
Forks static tipping load, full turn (40°)	kg				2.400
Forks Payload EN 474-3 (80%)	kg				1.920
Forks Payload EN 474-3 (60%)	kg				1.440
Breakout force	kg	5.400	5.800	5.100	/
Total length	mm	4.800	4.750	4.800	/
External bucket turning radius	mm	4.200	4.000	4.300	/
Standard operative weight	kg	4.350	4.700	4.700	/

TRANSMISSION

% Traction/Weight	71 %
Pump	500 bar
Hydrostatic engine	500 bar

WHEEL LOADER › “Z” LINKAGE



DIESEL ENGINE

4-cylinder engine: port fuel injection, water cooling, paper dry filtering. Emissions as per EC 97/68 stage IIIA rules.

Type	Yanmar 4TNV84T
Max Power	44 KW - 60 HP
Rated rpm	3.000
Power ISO/TR 14396	42 KW - 57 HP
Power EEC/80/1269	42 KW - 57 HP
Bore	mm 84
Stroke	mm 90
Displacement	cm ³ 1.995

ELECTRIC SYSTEM

Battery	12 Volt
Capacity EN 60095-1	100 Ah - 850 A
Alternator rating	40 A
Reverse warning	Standard
Wiring according to rules	IP 67 e DIN 40050

TRANSMISSION

Hydrostatic transmission with automatic power regulation and closed circuit with variable-displacement pump and engine. Two forward/reverse speeds with single-lever control.

	forward	reverse
1 st Gear km/h	0÷9	0÷9
2 nd Gear km/h	0÷30/34*	0÷30/34*

(*) High speed optional.

AXLES

All wheel drive. Two heavy duty axles with planetary final drives on each wheel. Fixed rigid drive axle on front chassis section. Oscillating drive axle on rear chassis section up to a 20° total angle. Transfer gearbox allowing the rear and the front movement by means of a transmission shaft. Self-locking limited slip differential on front axle (optional on rear axle).

BRAKES

Service: drum-brake hydraulically operating on front axle working on all wheels. Parking brake: mechanical drum-brake operating on service brake, manually activated.

TYRES

Standard	405/70 R18"
Optional	12,5-20" 12pr

STEERING

Servo assisted hydraulic steering with LOAD SENSING system.	
Total steering angle	80°
Inner tyres turning radius	mm 2.220
External tyres turning radius	mm 4.050
External bucket turning radius	mm 4.350

HYDRAULIC SYSTEM

Hydraulic gear pump with LOAD SENSING priority valve for steering circuit. 2-section modular control valve with main relief valve. Double-acting hydraulic cylinders. Hydraulic oil cooling radiator. Full-flow oil filter on the return circuit. Single control cloche-lever with 4-position bucket lifting system and 3-position auxiliary control system.

Max flow	lt/1'	60
Loader relief valve pressure	bar	230
Steering relief valve pressure	bar	190
Lift cylinder	mm	70x937
Bucket cylinder	mm	80x895

SERVICES CAPACITIES

Engine	lt	7,5
Front axle	lt	5,8
Rear axle + gear box	lt	6,5
Hydraulic circuit	lt	57
Brake system	lt	1,1
Fuel	lt	70
Water cooling	lt	10

TECHNICAL FEATURES

Standard bucket capacity	m ³	0,80
Bucket width	mm	1.900
Straight static tipping load	kg	3.850
Full turned 40° tipping load	kg	3.450
Lifting capacity at max. height	kg	2.500
Dump clearance	mm	3.200
Dump height at 40°	mm	2.600
Reach at 40°	mm	700
Breakout force	kg	5.300

DIMENSIONS AND WEIGHT

Max lenght in transfer position	mm	4.886
Max width in transfer position	mm	1.900
Max height	mm	2.550
Track width	mm	1.360
Overall tyre width	mm	1.820
Wheel base	mm	2.036
Ground clearance	mm	340
Standard operating weight	kg	4.900
Max permissible weight	kg	5.750

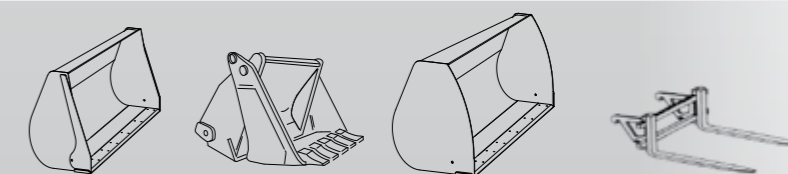
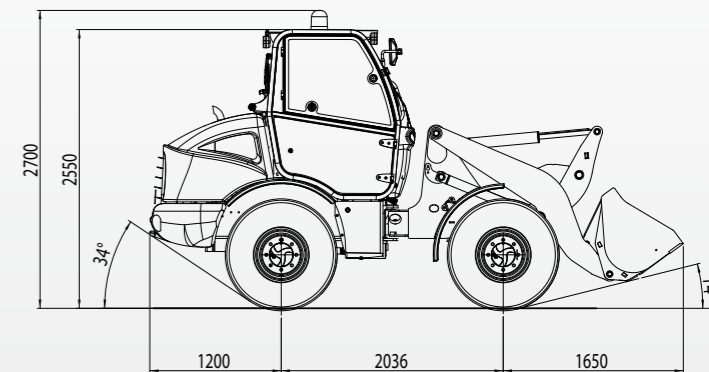
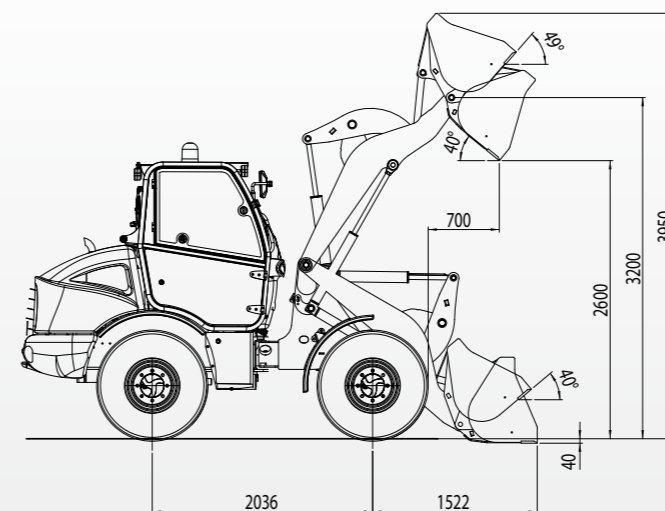

PERFORMANCE DATA

		UNIVERSAL BUCKET	MULTI PURPOSE BUCKET	OVERSIZE	FORKS
Full load bucket capacity (SAE)	m ³	0,8	0,7	1,5	/
Bucket width	mm	1.900	1.900	2.100	/
Bucket weight	kg	325	450	450	/
Max operative height	mm	3.950	3.750	3.900	/
Forks lengthh (Standard)	mm				1.000
Forks lengthh (Optional)	mm				1.200
Height to hinge pin	mm	3.200	3.200	3.200	/
Dump angle	°	40°	40°	40°	/
Dump height	mm	2.600	2.625	2.500	/
Reach fully raised	mm	700	730	750	/
Max dump distance	mm	2.000	1.950	2.100	/
Bucket static tipping load, straight	kg	3.850	4.100	3.650	/
Bucket static tipping load, full turn (40°)	kg	3.450	3.700	3.250	/
Forks static tipping load, full turn (40°)	kg				2.650
Forks Payload EN 474-3 (80%)	kg				2.120
Forks Payload EN 474-3 (60%)	kg				1.590
Breakout force	kg	4.700	5.000	4.400	/
Total length	mm	4.886	4.936	4.936	/
External bucket turning radius	mm	4.350	4.300	4.400	/
Standard operative weight	kg	4.900	5.000	5.000	/



80° articulation.

Cramped conditions do not scare us.



Steering console.

A master piece for all job requirements!

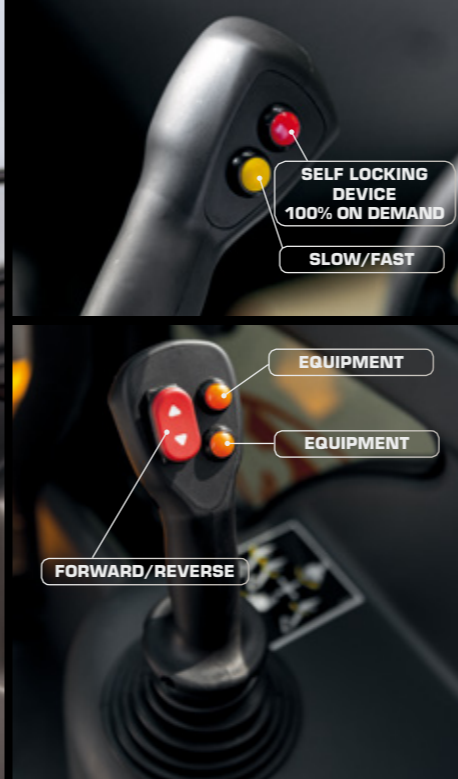

SELF LOCKING DEVICE
100% ON DEMAND

SLOW/FAST

EQUIPMENT

EQUIPMENT

FORWARD/REVERSE

Multipurpose Joystick.

You can do everything with one hand!



Hydraulic quick coupling.

Use your Venieri as a universal tool carrier thanks to the interchangeability of most quick couplings/equipment!



Linkage connection on the chassis with cantilevered pins.

+ performance, better visibility
= less risk!



Arms Connection with ovalized section.

We want to see clearly!



Framed glass door and flat glass.

We combine style with efficiency!



Evolved and complete hydraulic.

Not only High Flow kit but also additional hydraulic kit for tools and equipments. An example? Hand operated hydraulic demolition hammer!





EQUIPMENT

2.63C *Plus* 2.63C 3.63G

› Acoustic warnings	•	•	•
› Plugs with keys for fuel and hydraulic tanks	•	•	•
› Bucket with bolted teeth	•	•	•
› ROPS-FOPS cab with heating and pressurization fan, with front and rear windscreen wiper and windshield washer	•	•	•
› Tool box	•	•	•
› Spare parts catalogue	•	•	•
› Seat belt	•	•	•
› Electrically driven 100% blocking slip differential on front axle	•	•	•
› Safety clamp for lifting cylinders	•	•	•
› Visual index for bucket position	•	•	•
› Working lights	•	•	•
› Draw bar hook	•	•	•
› Soundproofing	•	•	•
› Yellow rotating and overturning beacon	•	•	•
› Operation and maintenance manual	•	•	•
› Type-approval for road traffic	•	•	•
› Side rearview mirrors	•	•	•
› Complete instrument panel	•	•	•
› Hydraulic or mechanical quick coupler	0	0	0
› Cement mixing bucket	0	0	0
› Multipurpose bucket (4 in 1)	0	0	0
› Speed reduction kit	0	0	0
› Lifting forks	0	0	0
› Proportional self lock rear differential	0	-	0
› Electrically driven 100% blocking slip differential on front axle; open on rear axle	•	-	0
› Asphalt and cement planer	0	0	0
› Snow blower	0	0	0
› "V" type snow blade	0	0	0
› Angle-tilt dozer blade	0	0	0
› Hand operating hammer	0	0	0
› Polishing brush	0	0	0
› Trencher	0	0	0

• Standard ◐ Optional - Not available



Via Piratello, 106 - 48022 Lugo (RA) ITALY
Tel. +39 0545 904411 Fax +39 0545 30389
e-mail: info@vf-venieri.com www.vf-venieri.com

Spare Parts
Tel. +39 0545 904429 Fax +39 0545 24555
e-mail: ricambi@vf-venieri.com